

Digitized Automation for a Changing World

Delta AC Servo Drive & Motor ASDA-A2R Series



www.deltaww.com

 **DELTA**
Smarter. Greener. Together.



A High Precision Direct Linear Motion Drive System for Backlash Free Motion Control

The ASDA-A2R Series is an innovative and high precision linear motion drive system that directly drives linear motors and optimally performs the tasks with high precision, high rigidity, high response and it is backlash free. This not only increases the work efficiency of the motion control system, but also expands the applications of the servo system.

The ASDA-A2R follows in the footsteps of Delta's high-performance servo system and provides the same functions such as high frequency response, auto notch filters, vibration and resonance suppression, flexible position register control PR mode, and supports DMCNET and CANopen communication interfaces. In addition, it also offers built-in electronic cam (E-CAM) that make the ASDA-A2R harmonize diverse linear motion control and robust servo drive to satisfy high precision requirements and increase productivity.

The ASDA-A2R provides more choices and drives not only Delta's but also other brands of linear motors and rotary permanent magnet synchronous servo motors. Connecting to an optional signal converter box through a motor encoder interface, the square waves and sine waves of feedback signals from the linear scale, linear motor and encoder can be converted to communication signals into the ASDA-A2R, and divided into high resolution signals to greatly reduce noise and distortion for offering accurate signal transmission that is essential for rapid and optimum communications.

Excellent performance, good stability, high reliability and flexibility are the features of Delta's ASDA-A2R Series linear motion drive system.



Table of Contents

3	ASDA-A2R Series Features
10	Product Line-up
11	Model Name Explanation
14	Servo Motor Features
15	ECMA Servo Motor Specifications
17	ECMA Servo Motor Dimensions
21	Part Names and Functions
23	Wiring
27	ASDA-Soft Configuration Software
29	Optional Accessories
31	Servo Drive Specifications
32	Servo Drive Dimensions
33	Optional Cables and Connectors
38	Safety Information
39	Servo Drive, Servo Motor and Accessories Combinations
42	Other Accessories
42	Regenerative Resistor Specifications

ASDA-A2R Series Features

System Operation with High Flexibility:

Connecting Various Kinds of Linear Motors and Servo Motors

- Support for Delta's permanent-magnet synchronous linear motors and servo (rotary) motors.
- Support for other brands of permanent-magnet synchronous linear motors and servo (rotary) motors.



ECMA Series Servo Motors



ECML Series Linear Motors

For different feedback configurations, please refer to the following recommended wiring methods for connecting the ASDA-A2R Series linear motion drive.

1. Using Delta's ECMA Series servo motor.
2. When not using Delta's servo motor and if the encoder signals are sinewave, the sine wave can be converted into communication signals by Delta's Signal Converter Box through the CN2 connector for the use of Delta's ASDA-A2R servo system.
3. When not using Delta's servo motor and if the encoder signals are square wave, the square wave can be converted into communication signals directly through the CN5 connector for the use of Delta's ASDA-A2R servo system.

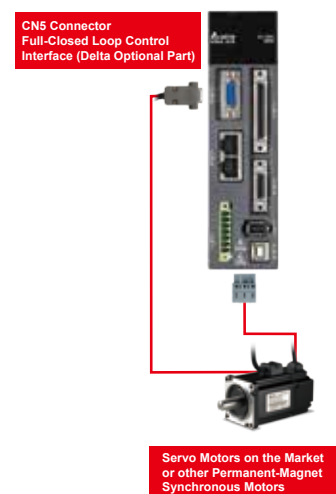
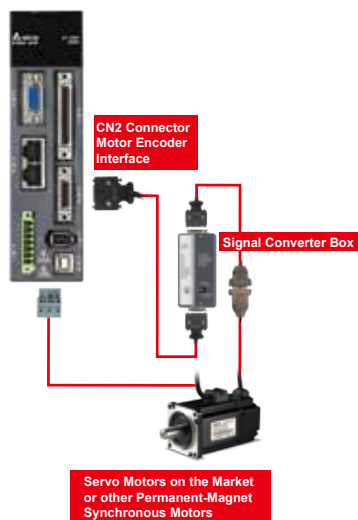
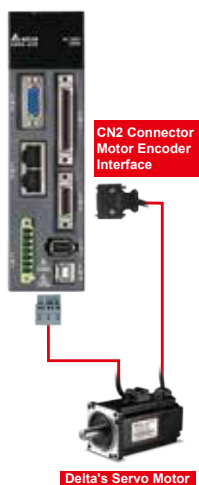

4. When using the linear motor with a linear scale and if the encoder signals are sine wave, the sine wave can be converted into communication signals by Delta's Signal Converter Box through the CN2 connector for the use of Delta's ASDA-A2R servo system.

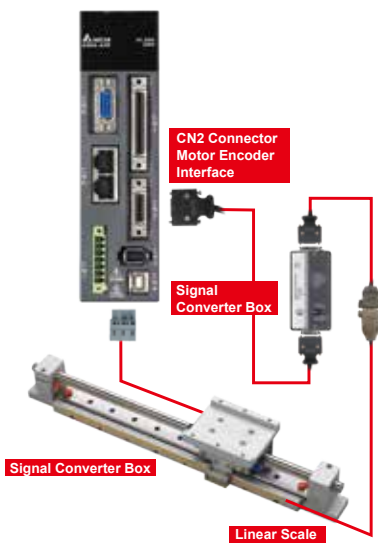

5. When using the linear motor with a linear scale and if the encoder signals are square wave, the square wave can be converted into communication signals directly through the CN5 connector for the use of Delta's ASDA-A2R servo system. In addition, when a Hall Sensor is included and placed in-between, the signal can be transmitted via CN5 connector and controlled.

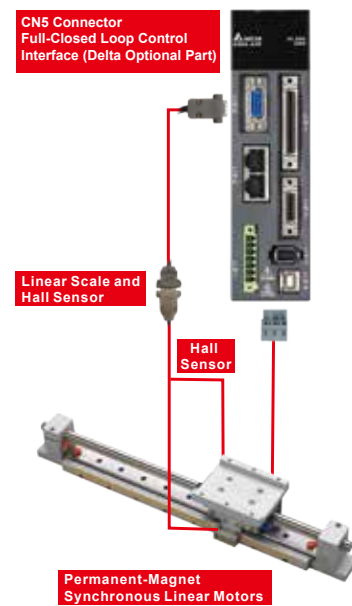

Satisfying Customers' High Speed

Communication Requirements:

The ASD-IF-EN0A20 Signal Converter Box (optional)

- Converts the square wave and sine wave to communication signals that can be used and controlled by Delta's servo drive.
- Supports AB phase square waves of digital signals and sine waves of analog signals.
- Divides signals up to 2,048 times for accurate signal transmission and enhanced positioning resolution.
- Delivers original signals over 20m without attenuation to ensure communication quality.



ASDA-A2R Series Features

Simple Setup Procedures Make Motor Connection Quick and Effortless

- Easy-to-operate and step-by-step procedures help users quickly complete motor setup and connection.



Intelligent Motor Parameter Measuring and Tuning

- Detects related electrical circuit parameters such as motor inductance and resistance.
- Provides motor current loop parameters for motor auto-tuning.
- Measures initial conditions on the magnetic field amplification and corrects phase sequence and deviation values of Hall sensor unit
- Detects and offsets the phase sequence of the motor's U, V, W terminals

Excellent Suppression Functions

- Vibration Suppression (Low Frequency)
Vibration suppression filters are provided for long arm systems to minimize vibration at the machine edges effectively.
- Resonance Suppression (High Frequency)
Auto notch filters are provided to suppress mechanical resonance efficiently.

Accurate Positioning and Initiation without a Hall Sensor

- Keeps high positioning accuracy and reliability while the motor is running without connecting a Hall sensor unit.
- Detects the angle of a motor magnet by fine-sensing to ensure that magnetic field lines are passing at right angles at power-on.

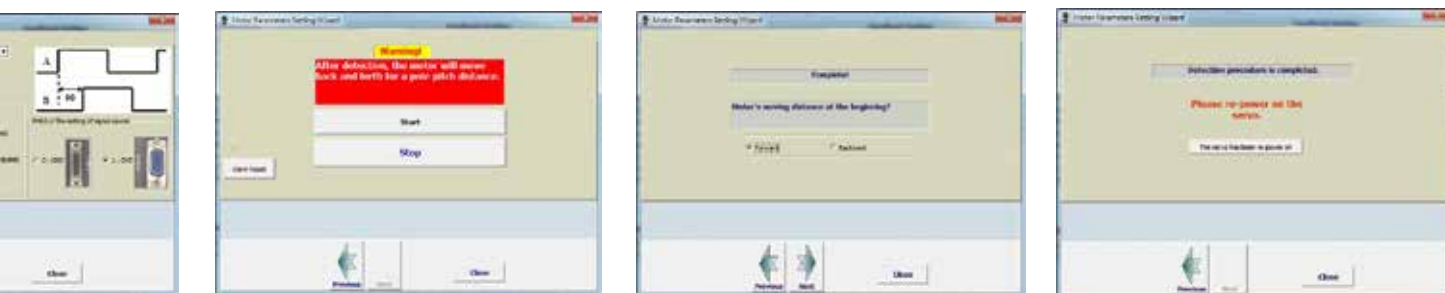

Detection and Compensation of Motor Cogging Force

- After the generated cogging force is reduced, the operation of the motor is more smooth and stable.

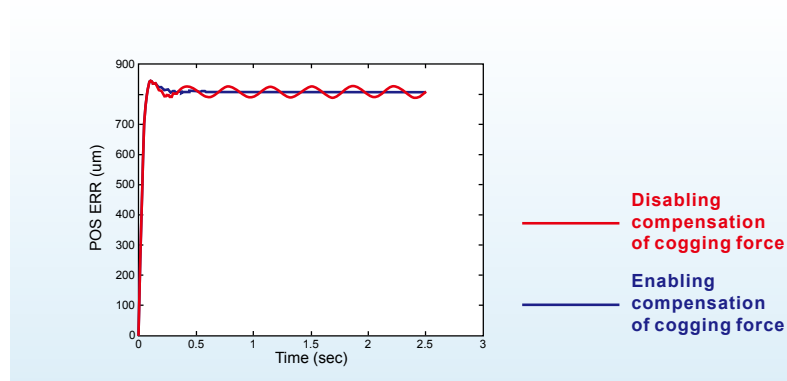

ASDA-A2R Series Features

Full-Closed Loop Control Function

- Reduces the effects of backlash and flexibility from the machine and ensures the accuracy of positioning.

Built-in Electronic CAM (E-CAM) Function

- 720 points max. for E-CAM outline.
- Smooth interpolation between points can be completed automatically to yield flexible programming.
- ASDA-Soft configuration software provides an E-CAM profile editing function for easy tuning and adjustment.
- Easy to use for flying shear, rotary cut, and other cam applications.

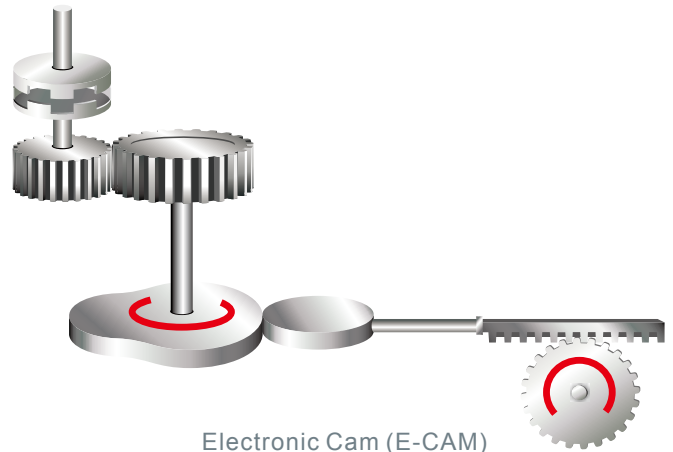

Versatile PR Mode

- ASDA-Soft configuration software offers a parameters editing function for different procedures planning.
- In PR mode, 64 procedures can be applied for multiple axes to enhance the ability of multiple points and continuous position control.
- Motion profile such as target position, speed command, acceleration and deceleration control can be changed instantaneously.
- 35 Homing modes / Jump mode / Write parameter mode / Constant speed mode / Position control mode supported.

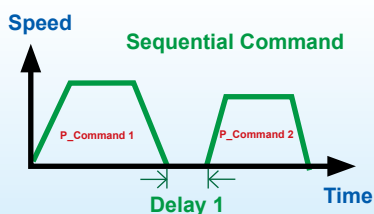

A command is executed only when the previous command is completed.

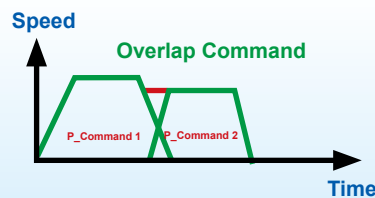

The speed command is executed after the delay time or during the deceleration period.

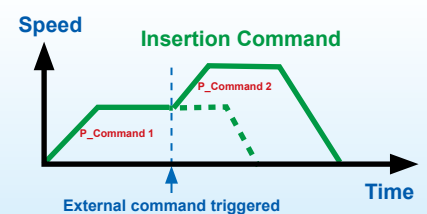

Insertion changes the commands executed at the moment it is inserted.

Real Time Capture and Compare Functions

High-speed Position Latch Function (Capture)

- Latches the coordinate value on the reference axis.
- Response time is less than 5us.
- It can be used to do mark tracking applications.
- Maximum 800 records.

High-speed Position Detection Function (Compare)

- Detects the location on the reference axis.
- Response time is less than 5us.
- Maximum 800 records.

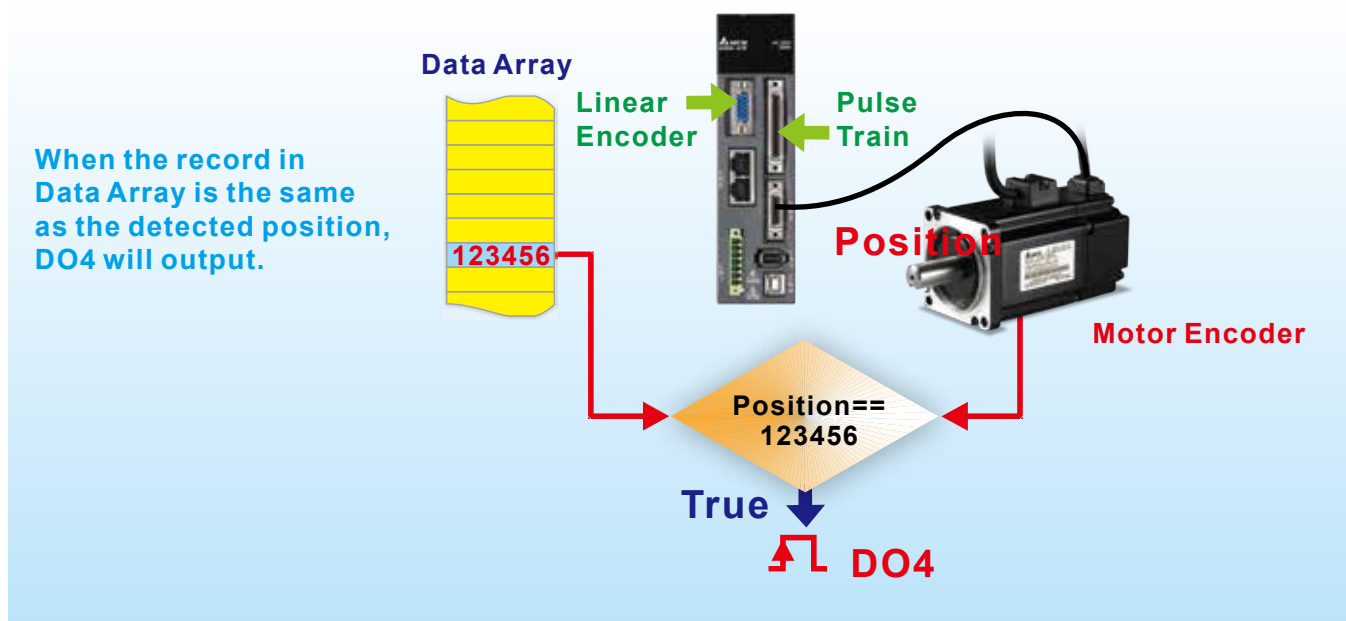
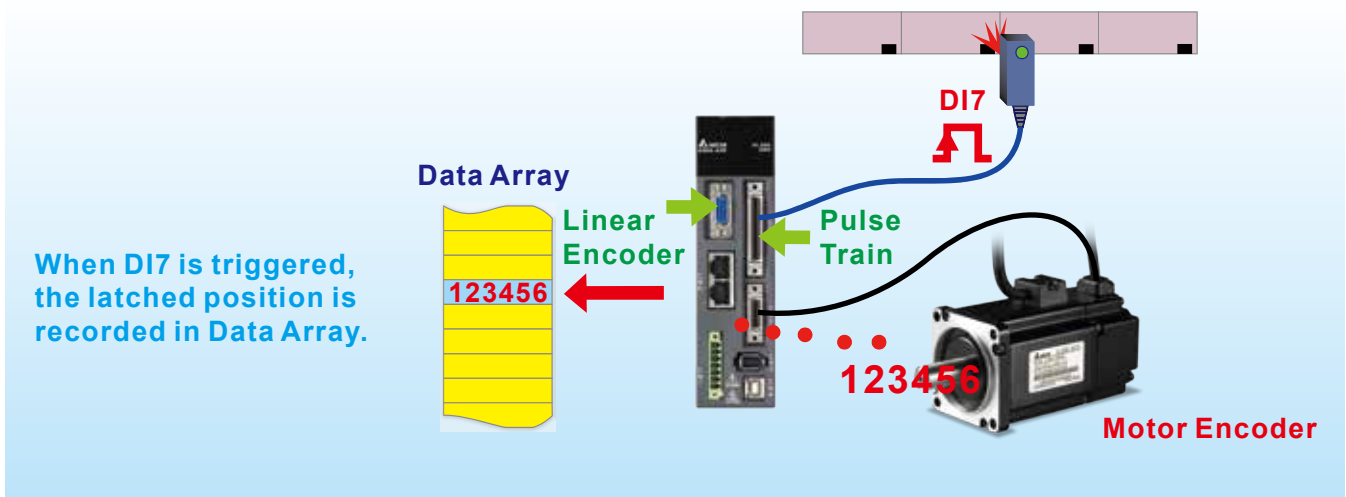

ASDA-A2R Series Features

Realization of Fieldbus Control System (Supports CANopen)

- Complies with CANopen DS301 protocol, providing up to 1 Mbps communication rate.
- Supports motion control modes via the CANopen DS402 protocol.
- With the aid of Delta's PLC, it can save on wiring and establish a Delta fieldbus system configuration.
- Capable of reading and writing servo drive parameters in any mode through CANopen communication.

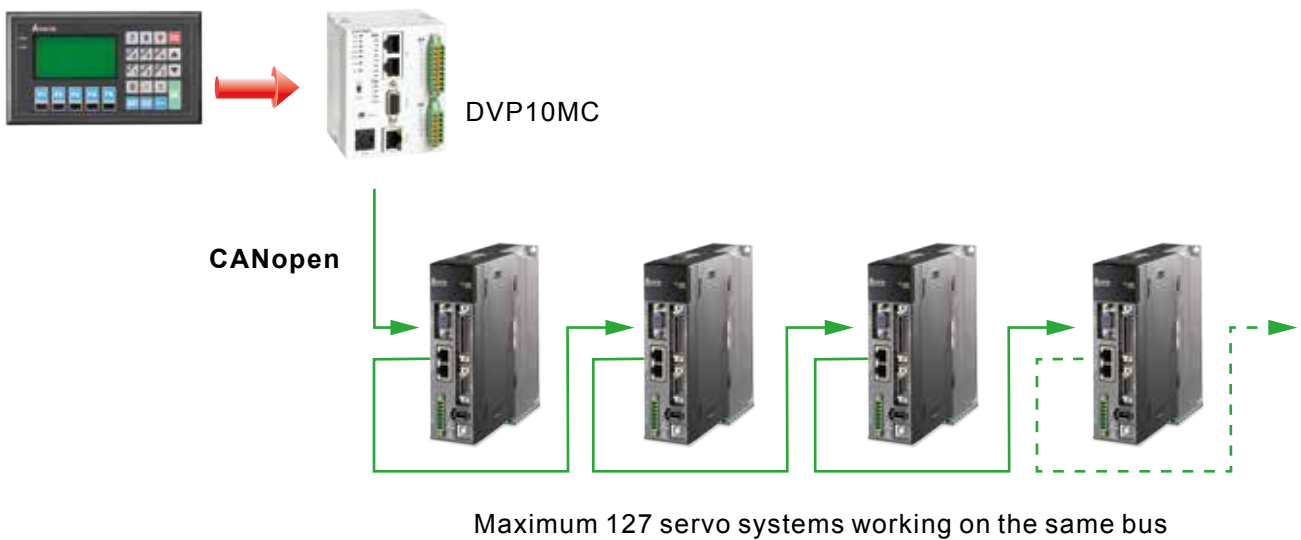

Delta High-Speed Communication Network



Product Line-up

Servo Drives								
	100W	200W	400W	750W	1.0kW	1.5kW	2.0kW	3.0kW
	ASD-A2R-0121-□	ASD-A2R-0221-□	ASD-A2R-0421-□	ASD-A2R-0721-□	ASD-A2R-1021-□	ASD-A2R-1521-□	ASD-A2R-2023-□	ASD-A2R-3023-□

Permanent-magnet Synchronous Servo (Rotary) Motors								
	ECMA-CΔ0401□S ECMA-C1040F□S	ECMA-CΔ0602□S	ECMA-CΔ0604□S ECMA-CΔ0804□7 ECMA-EΔ1305□S ECMA-GΔ1303□S	ECMA-CΔ0807□S ECMA-CΔ0907□S ECMA-GΔ1306□S ECMA-F11305□S	ECMA-CΔ0910□S ECMA-CΔ1010□S ECMA-EΔ1310□S ECMA-FΔ1308□S ECMA-GΔ1309□S	ECMA-EΔ1315□S	ECMA-CΔ1020□S ECMA-CΔ1320□S ECMA-EΔ1820□S ECMA-F11313□S ECMA-F11318□S	ECMA-EΔ1830□S ECMA-CΔ1330□4 ECMA-FΔ1830□S ECMA-EΔ1835□S

Permanent-magnet Synchronous Linear Motors							-	
	ECML-S1606A2DNS ECML-S1608A2DNS	ECML-S2003A2DNS ECML-S2004A2DNS ECML-S2005A2DNS	ECML-S2504A2DNS ECML-S2506A2DNS ECML-S3204A2DNS	ECML-S2508A2DNS ECML-S3206A2DNS ECML-S3208A2DNS ECML-S3505A2DNS	ECML-S3506A2DNS	-	-	-

NOTE 1) The boxes (□) at the ends of the servo drive model names are for the model type of ASDA-A2R. For the actual model name, please refer to the purchased product and the model explanation of the servo drive.
 2) The boxes (□) in the servo motor model names are for encoder resolution types (□=1: incremental, 20-bit; □=2: incremental, 17-bit).
 3) The boxes (□) in the servo motor model names are for motor shaft specifications (□=1: incremental, 20-bit; □=2: incremental, 17-bit).
 4) The model names of the linear motors are the type of coil assembly (rotor).
 For the type of magnetic way (stator), please refer to the model explanation of the ECML Series Servo Motor on page 13.

Model Name Explanation

ASDA-A2R Series Servo Drive

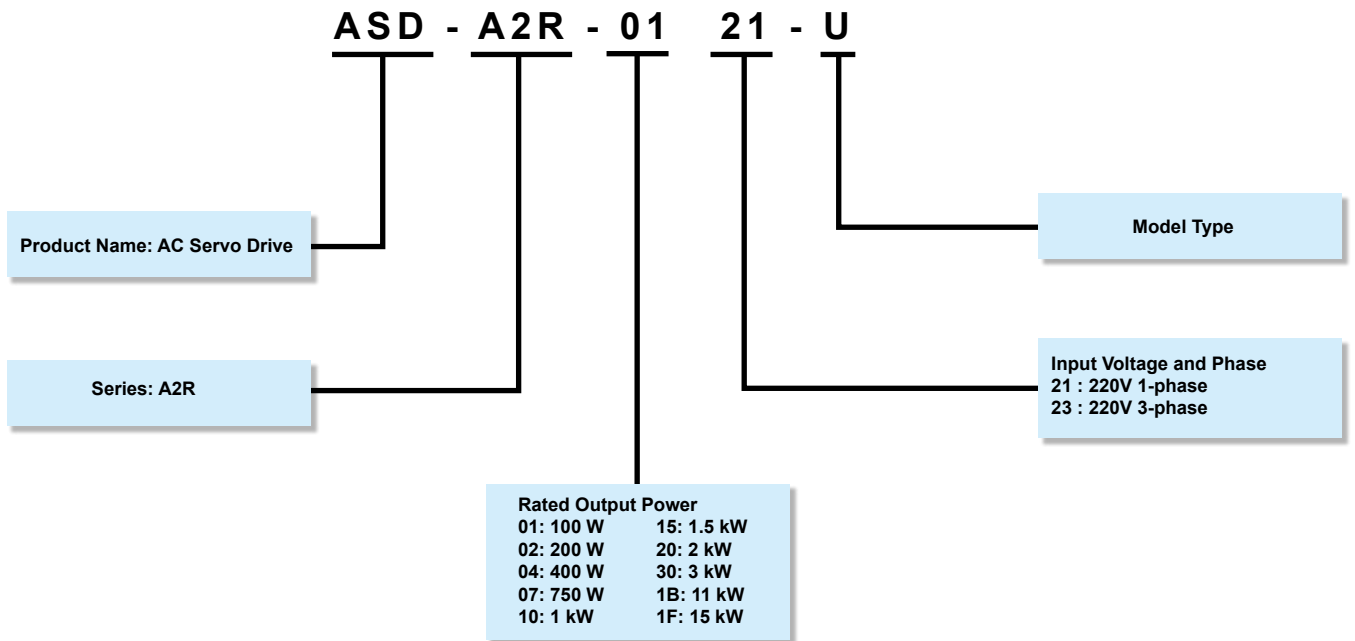

Model Type

	Type	RS-485 (CN3)	Full-Closed Control (CN5) ¹	Extension Port for Digital Input (CN7)	CANpen	DMCNET	Analog Voltage Control	Pulse Input Port	PR Parameters ²	E-CAM ³
Standard Model	L	○	○	X	X	X	○	○	○	X
	U	○	○	○	X	X	○	○	○	○
Network Model	F	○	○	X	X	○	X	X	○	X
	M	○	○	X	○	X	○	○	○	○

NOTE

1. In PR mode, only A2R-F supports full-closed control function.
2. When applying communication mode (A2R-F, A2R-M models), PR parameters can be read and written through DMCNET only.
3. E-CAM function can only be used in PR mode

ECMA Series Servo Motor

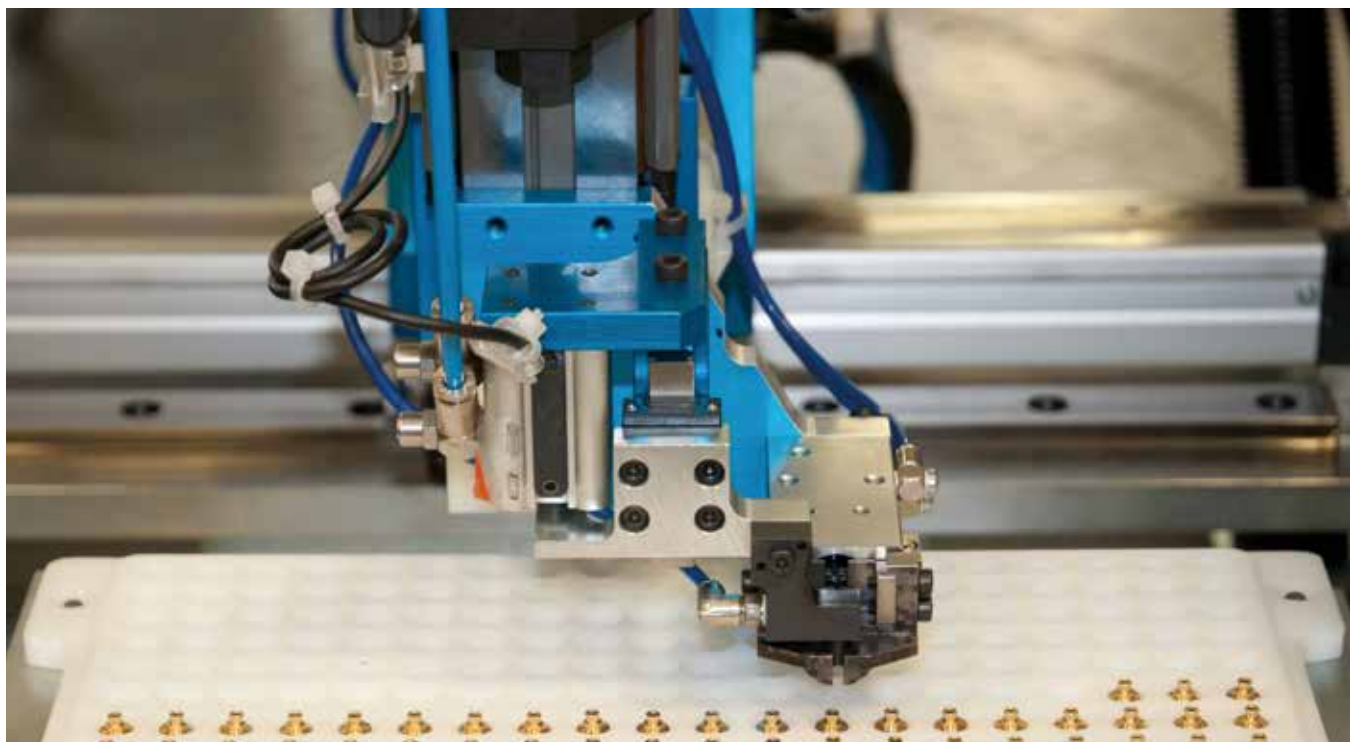
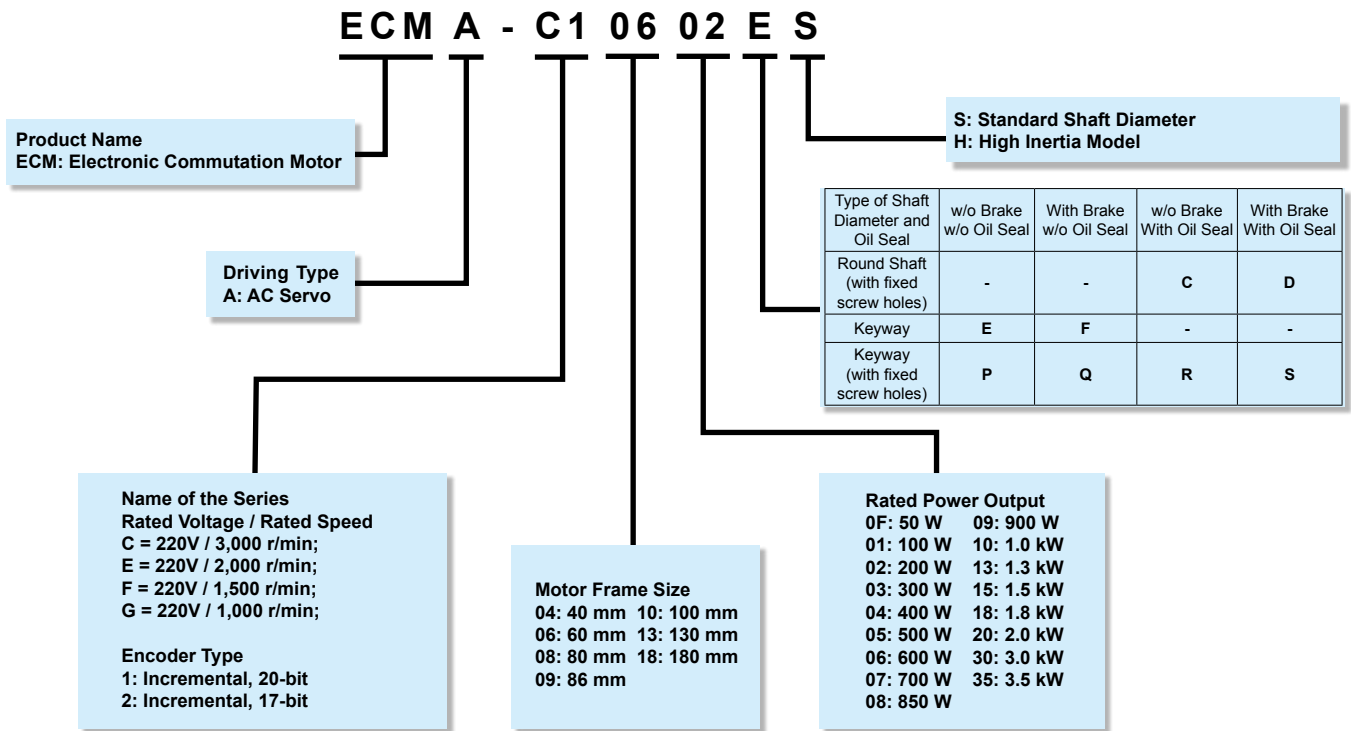

Ordering Information

ECML Series Linear Motor - Coil Assembly Model

ECML - S 1608 A 2 D N S
 ① ② ③ ④ ⑤ ⑥ ⑦

①	ECML	Product	ECML: Linear Motor					
	S	Linear Motor Type	S: Shaft Type Coreless					
②	1608	Magnetic Way Dimensions	Magnetic Way Diameter (mm)	Ø16	Ø20	Ø25	Ø32	Ø35
			Codes	1606	2003	2504	3204	3505
				1608	2004	2506	3206	3506
					2005	2508	3208	
③	A	Wiring Method	A: Wiring Method A					
④	2	Input Voltage	2 : 220 V					
⑤	D	Hall Sensor Type	D: Digital					
⑥	N	Cooling Type	N : N/A					
⑦	S	Special Order	Delta Standard Product					

ECML Series Linear Motor - Magnetic Way Model

ECML - SM 16 1000
 ① ② ③

	ECML	Product	ECML: Linear Motor		
①	SM	Linear Motor Type	S: Shaft Type Coreless		
②	16	Magnetic Way Diameter	16 : Ø16 mm 20 : Ø20 mm	25 : Ø25 mm 32 : Ø32 mm	35 : Ø35 mm
③	1000	Magnetic Way Length	Range: 250~2310 mm	E.g.: 0340 : 340 mm 0520 : 520 mm 1060 : 1060 mm	

Note:
For product features and detailed specifications of ECML Series linear motors, please refer to the catalogue of Delta Linear Motion Products.

Servo Motor Features

ECMA

ECMA Series servo motors are permanent-magnet AC servo motors, capable of combining with 200V to 230V ASDA-A2R Series AC servo drives from 50W to 3.5kW. There are seven frame sizes available: 40 mm, 60 mm, 80 mm, 86 mm, 100 mm, 130 mm and 180 mm. The motor speed is from 1000 r/min to 5000 r/min and maximum torque range is between 0.477N-m to 57.29N-m.

For optional configurations, the ECMA Series provides brake and oil seal models to fully support customer needs. It also offers two different shaft selections, round shaft and keyway, for various applications.

ECML

ECML Series linear motors are permanent-magnet synchronous linear motors which feature:

- Built-in digital hall sensor: When a ECML motor is re-servo on, it can find the phase angle without moving.
- Built-in temperature sensor: A thermistor type of temperature sensor is installed inside the ECML motor. Users can acquire the motor's internal temperature by servo drive or ohmmeter.
- Coil assembly has two sides of mounting holes: This allows users to have more flexibility and expandability for device installation.



Specifications of ECMA Series Servo Motors

Low Inertia Series

ECMA	C104	C △ 04	C △ 06		C △ 08		C △ 09		C △ 10		C △ 13
	0F	01	02	04 □ S	04	07	07	10	10	20	30
Rated power (kW)	0.05	0.1	0.2	0.4	0.4	0.75	0.75	1.0	1.0	2.0	3.0
Rated torque (N-m) ^{*1}	0.159	0.32	0.64	1.27	1.27	2.39	2.39	3.18	3.18	6.37	9.55
Max. torque (N-m)	0.477	0.96	1.92	3.82	3.82	7.16	7.14	8.78	9.54	19.11	28.65
Rated speed (r/min)	3000						3000		3000		3000
Max. speed (r/min)	5000						3000		5000		4500
Rated current (A)	0.69	0.90	1.55	2.6	2.6	5.1	3.66	4.25	7.3	12.05	17.2
Max. instantaneous current (A)	2.05	2.70	4.65	7.8	7.8	15.3	11	12.37	21.9	36.15	47.5
Max. power per second (kW/s)	12.27	27.7	22.4	57.6	24.0	50.4	29.6	38.6	38.1	90.6	71.8
Rotor inertia (x10-4kg-m ²)	0.0206	0.037	0.177	0.277	0.68	1.13	1.93	2.62	2.65	4.45	12.7
Mechanical constant (ms)	1.2	0.75	0.80	0.53	0.74	0.63	1.72	1.20	0.74	0.61	1.11
Torque constant-KT(N-m/A)	0.23	0.36	0.41	0.49	0.49	0.47	0.65	0.75	0.44	0.53	0.557
Voltage constant -KE(mV/(r/min))	9.8	13.6	16	17.4	18.5	17.2	24.2	27.5	16.8	19.2	20.98
Armature resistance (Ohm)	12.7	9.30	2.79	1.55	0.93	0.42	1.34	0.897	0.20	0.13	0.0976
Armature inductance (mH)	26	24.0	12.07	6.71	7.39	3.53	7.55	5.7	1.81	1.50	1.21
Electric constant (ms)	2.05	2.58	4.3	4.3	7.96	8.36	5.66	6.35	9.3	11.4	12.4
Insulation class	Class A (UL), Class B (CE)										
Insulation resistance	> 100MΩ · DC 500V										
Insulation strength	1.8k Vac, 1 sec										
Weight – without brake (kg)	0.42	0.5	1.2	1.6	2.1	3.0	2.9	3.8	4.3	6.2	7.8
Weight – with brake (kg)	--	0.8	1.5	2.0	2.9	3.8	3.69	5.5	4.7	7.2	9.2
Radial max. loading (N)	78.4	78.4	196	196	245	245	245	245	490	490	490
Axial max. loading (N)	39.2	39.2	68	68	98	98	98	98	98	98	98
Max. power per second (kW/s) (with brake)	--	25.6	21.3	53.8	22.1	48.4	29.3	37.9	30.4	82	65.1
Rotor inertia (x10-4kg-m ²) (with brake)	--	0.04	0.19	0.30	0.73	1.18	1.95	2.67	3.33	4.95	14.0
Mechanical constant (ms) (with brake)	--	0.81	0.85	0.57	0.78	0.65	1.74	1.22	0.93	0.66	1.22
Brake holding torque [N-t (min)] ^{*2}	--	0.3	1.3	1.3	2.5	2.5	2.5	2.5	8	8	10.0
Brake power consumption (at 20°C)[W]	--	7.3	6.5	6.5	8.2	8.2	8.2	8.2	18.7	18.7	19.0
Brake release time [ms (Max)]	--	5	10	10	10	10	10	10	10	10	10
Brake pull-in time [ms (Max)]	--	25	70	70	70	70	70	70	70	70	70
Vibration grade (μm)	15										
Operating temperature (°C)	0°C to 40°C (32°F to 104°F)										
Storage temperature (°C)	-10°C to 80°C (-14°F to 176°F)										
Operating humidity	20 to 90%RH (non-condensing)										
Storage humidity	20 to 90%RH (non-condensing)										
Vibration capacity	2.5G										
IP rating	IP65 (use the waterproof connector and shaft seal installation (or oil seal))										
Certification											

Note:

*1 The rated torque is the continuous permissible torque between 0~40°C operating temperature which is suitable for the following heat sink dimensions.

ECMA-__ 04 / 06 / 08 : 250mm x 250mm x 6mm

ECMA-__ 10 : 300mm x 300mm x 12mm

ECMA-__ 13 : 400mm x 400mm x 20mm

ECMA-__ 18 : 550mm x 550mm x 30mm

Material: Aluminum – F40, F60, F80, F100, F130, F180

*2 The built-in brake of the servo motor is for keeping the item in stop status. Do not use it to decelerate or as a dynamic brake.

Medium/High inertia Series

ECMA	E △ 13				E △ 18			G △ 13			F △ 13	F △ 13	F △ 18	F113	
	05	10	15	20	20	30	35	03	06	09	05	08	30	13	18
Rated power (kW)	0.5	1.0	1.5	2.0	2.0	3.0	3.5	0.3	0.6	0.9	0.5	0.85	3.0	1.3	1.8
Rated torque (N-m) ^{*1}	2.39	4.77	7.16	9.55	9.55	14.32	16.71	2.86	5.73	8.59	3.18	5.41	19.10	8.34	11.48
Max. torque (N-m)	7.16	14.3	21.48	28.65	28.65	42.97	50.13	8.59	17.19	21.48	8.92	13.8	57.29	23.3	28.7
Rated speed (r/min)	2000						1000						1500		
Max. speed (r/min)	3000						2000						3000		
Rated current (A)	2.9	5.6	8.3	11.01	11.22	16.1	19.2	2.5	4.8	7.5	3.9	7.1	19.4	12.6	13
Max. instantaneous current (A)	8.7	16.8	24.9	33.03	33.66	48.3	57.6	7.5	14.4	22.5	12.1	19.4	58.2	38.6	36
Max. power per second (kW/s)	7.0	27.1	45.9	62.5	26.3	37.3	50.8	10.0	39.0	66.0	9.8	21.52	66.4	34.78	52.93
Rotor inertia (x10-4kg-m ²)	8.17	8.41	11.18	14.59	34.68	54.95	54.95	8.17	8.41	11.18	10.3	13.6	54.95	20	24.9
Mechanical constant (ms)	1.91	1.51	1.10	0.96	1.62	1.06	1.08	1.84	1.40	1.06	2.8	2.43	1.28	1.62	1.7
Torque constant-KT(N-m/A)	0.83	0.85	0.87	0.87	0.85	0.89	0.87	1.15	1.19	1.15	0.82	0.76	0.98	0.66	0.88
Voltage constant -KE(mV/(r/min))	30.9	31.9	31.8	31.8	31.4	32.0	32	42.5	43.8	41.6	29.5	29.2	35.0	24.2	32.2
Armature resistance (Ohm)	0.57	0.47	0.26	0.174	0.119	0.052	0.052	1.06	0.82	0.43	0.624	0.38	0.077	0.124	0.185
Armature inductance (mH)	7.39	5.99	4.01	2.76	2.84	1.38	1.38	14.29	11.12	6.97	7	4.77	1.27	1.7	2.6
Electric constant (ms)	12.96	12.88	15.31	15.86	23.87	26.39	26.39	13.5	13.50	16.06	11.22	12.55	16.5	13.71	14.05
Insulation class	A 級 (UL) · B 級 (CE)														
Insulation resistance	100MΩ · DC 500V 以上														
Insulation strength	1.8k Vac, 1 sec														
Weight – without brake (kg)	6.8	7.0	7.5	7.8	13.5	18.5	18.5	6.8	7.0	7.5	6.3	8.6	18.5	9.4	10.5
Weight – with brake (kg)	8.2	8.4	8.9	9.2	17.5	22.5	22.5	8.2	8.4	8.9	7.7	10.0	22.5	10.8	11.9
Radial max. loading (N)	490	490	490	490	1176	1470	490	490	490	490	490	490	1470	490	490
Axial max. loading (N)	98	98	98	98	490	490	98	98	98	98	98	98	490	98	98
Max. power per second (kW/s) (with brake)	6.4	24.9	43.1	57.4	24.1	35.9	48.9	9.2	35.9	62.1	8.8	19.78	63.9	32.66	50.3
Rotor inertia (x10-4kg-m ²) (with brake)	8.94	9.14	11.90	15.88	37.86	57.06	57.06	8.94	9.14	11.9	11.5	14.8	57.06	21.3	26.2
Mechanical constant (ms) (with brake)	2.07	1.64	1.19	1.05	1.77	1.10	1.12	2.0	1.51	1.13	3.12	2.65	1.33	1.73	1.79
Brake holding torque [Nt·m (min)] ^{*2}	10.0	10.0	10.0	10.0	25.0	25.0	25.0	10.0	10.0	10.0	10	10.0	25.0	10.0	10.0
Brake power consumption (at 20°C)[W]	19.0	19.0	19.0	19.0	20.4	20.4	20.4	19.0	19.0	19.0	19	19.0	20.4	19.0	19.0
Brake release time [ms (Max)]	10	10	10	10	10	10	10	10	10	10	10	10	10	10	10
Brake pull-in time [ms (Max)]	70	70	70	70	70	70	70	70	70	70	70	70	70	70	70
Vibration grade (μm)	15														
Operating temperature (°C)	0°C to 40°C (32°F to 104°F)														
Storage temperature (°C)	-10°C to 80°C (-14°F to 176°F)														
Operating humidity	20 to 90%RH (non-condensing)														
Storage humidity	20 to 90%RH (non-condensing)														
Vibration capacity	2.5G														
IP rating	IP65 (use the waterproof connector and shaft seal installation (or oil seal))														
Certification															

Note:

*1 The rated torque is the continuous permissible torque between 0~40°C operating temperature which is suitable for the following heat sink dimensions.

ECMA-__ 04 / 06 / 08 : 250mm x 250mm x 6mm

ECMA-__ 10 : 300mm x 300mm x 12mm

ECMA-__ 13 : 400mm x 400mm x 20mm

ECMA-__ 18 : 550mm x 550mm x 30mm

Material: Aluminum – F40, F60, F80, F100, F130, F180

*2 The built-in brake of the servo motor is for keeping the item in stop status. Do not use it to decelerate or as a dynamic brake.

Dimensions of ECMA Series Servo Motors

Motor Frame Size: 86 or below

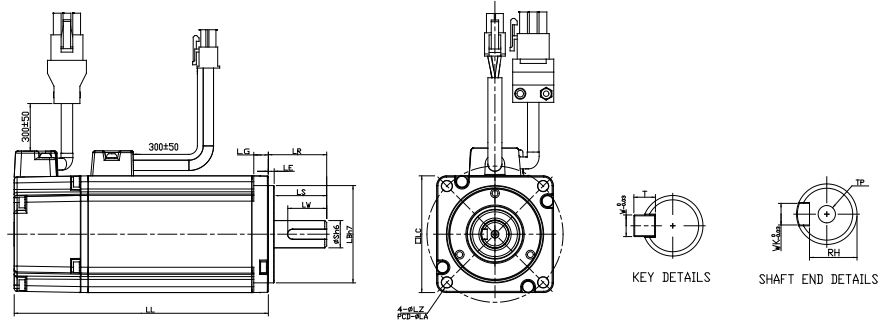

Units: mm

Model	C1040F □ S	C △ 0401 □ S	C △ 0602 □ S	C △ 0604 □ S	C △ 0604 □ H	C △ 0804 □ 7	C △ 0807 □ S	C △ 0807 □ H	C △ 0907 □ S	C △ 0910 □ S	
LC	40	40	60	60	60	80	80	80	86	86	
LZ	4.5	4.5	5.5	5.5	5.5	6.6	6.6	6.6	6.6	6.6	
LA	46	46	70	70	70	90	90	90	100	100	
S	8 (+0/-0.009)	8 (+0/-0.009)	14 (+0/-0.011)	14 (+0/-0.011)	14 (+0/-0.011)	14 (+0/-0.011)	19 (+0/-0.013)	19 (+0/-0.013)	16 (+0/-0.011)	16 (+0/-0.011)	
LB	30 (+0/-0.021)	30 (+0/-0.021)	50 (+0/-0.025)	50 (+0/-0.025)	50 (+0/-0.025)	70 (+0/-0.030)	70 (+0/-0.030)	70 (+0/-0.030)	80 (+0/-0.030)	80 (+0/-0.030)	
LL(without brake)	79.1	100.6	105.5	130.7	145.8	112.3	138.3	154.8	130.2	153.2	
LL (with brake)	--	136.8	141.6	166.8	176.37	152.8	178	187.8	161.3	184.3	
LS	20	20	27	27	27	27	32	32	30	30	
LR	25	25	30	30	30	30	35	35	35	35	
LE	2.5	2.5	3	3	3	3	3	3	3	3	
LG	5	5	7.5	7.5	7.5	8	8	8	8	8	
LW	16	16	20	20	20	20	25	25	20	20	
RH	6.2	6.2	11	11	11	11	15.5	15.5	13	13	
WK	3	3	5	5	5	5	6	6	5	5	
W	3	3	5	5	5	5	6	6	5	5	
T	3	3	5	5	5	5	6	6	5	5	
TP	M3 Depth 8	M3 Depth 8	M4 Depth 15	M4 Depth 15	M4 Depth 15	M4 Depth 15	M4 Depth 15	M6 Depth 20	M6 Depth 20	M5 Depth 15	M5 Depth 15

- NOTE**
- 1) Dimensions are in millimeters.
 - 2) Dimensions and weights might be revised without prior notice.
 - 3) Box, (□) represents the shaft end/ brake or the number of oil seal.
 - 4) The boxes (△) in the model names are for encoder resolution types (△=1: Incremental encoder, 20-bit; △=2: Incremental encoder, 17-bit).

Torque Features (T-N Curve)

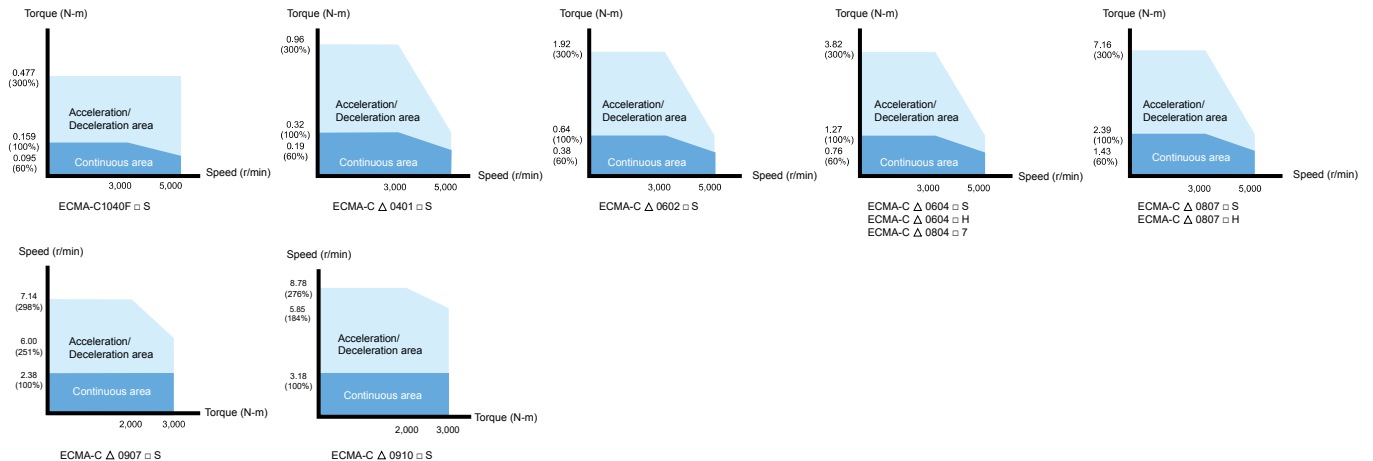

Motor Frame Size: 100 ~ 130

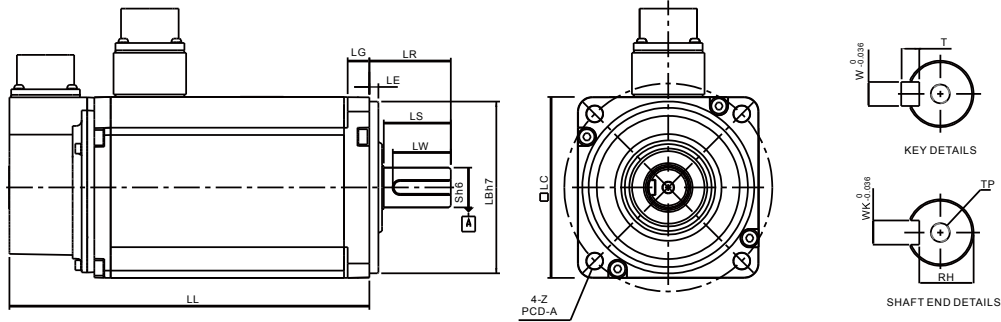

Units: mm

Model	C Δ 1010 \square S	C Δ 1020 \square S	C Δ 1330 \square 4	E Δ 1305 \square S	E Δ 1310 \square S	E Δ 1315 \square S	E Δ 1320 \square S
LC	100	100	130	130	130	130	130
LZ	9	9	9	9	9	9	9
LA	115	115	145	145	145	145	145
S	22 ($^{+0}_{-0.013}$)	22 ($^{+0}_{-0.013}$)	24 ($^{+0}_{-0.013}$)	22 ($^{+0}_{-0.013}$)	22 ($^{+0}_{-0.013}$)	22 ($^{+0}_{-0.013}$)	22 ($^{+0}_{-0.013}$)
LB	95 ($^{+0}_{-0.035}$)	95 ($^{+0}_{-0.035}$)	110 ($^{+0}_{-0.035}$)	110 ($^{+0}_{-0.035}$)	110 ($^{+0}_{-0.035}$)	110 ($^{+0}_{-0.035}$)	110 ($^{+0}_{-0.035}$)
LL (without brake)	153.3	199	187.5	147.5	147.5	167.5	187.5
LL (with brake)	192.5	226	216	183.5	183.5	202	216
LS	37	37	47	47	47	47	47
LR	45	45	55	55	55	55	55
LE	5	5	6	6	6	6	6
LG	12	12	11.5	11.5	11.5	11.5	11.5
LW	32	32	36	36	36	36	36
RH	18	18	20	18	18	18	18
WK	8	8	8	8	8	8	8
W	8	8	8	8	8	8	8
T	7	7	7	7	7	7	7
TP	M6 Depth 20	M6 Depth 20	M6 Depth 20	M6 Depth 20	M6 Depth 20	M6 Depth 20	M6 Depth 20

- NOTE**
- 1) Dimensions are in millimeters.
 - 2) Dimensions and weights might be revised without prior notice.
 - 3) Box, (\square) represents the shaft end/ brake or the number of oil seal.
 - 4) The boxes (Δ) in the model names are for encoder resolution types ($\Delta=1$: Incremental encoder, 20-bit; $\Delta=2$: Incremental encoder, 17-bit).

Torque Features (T-N Curve)

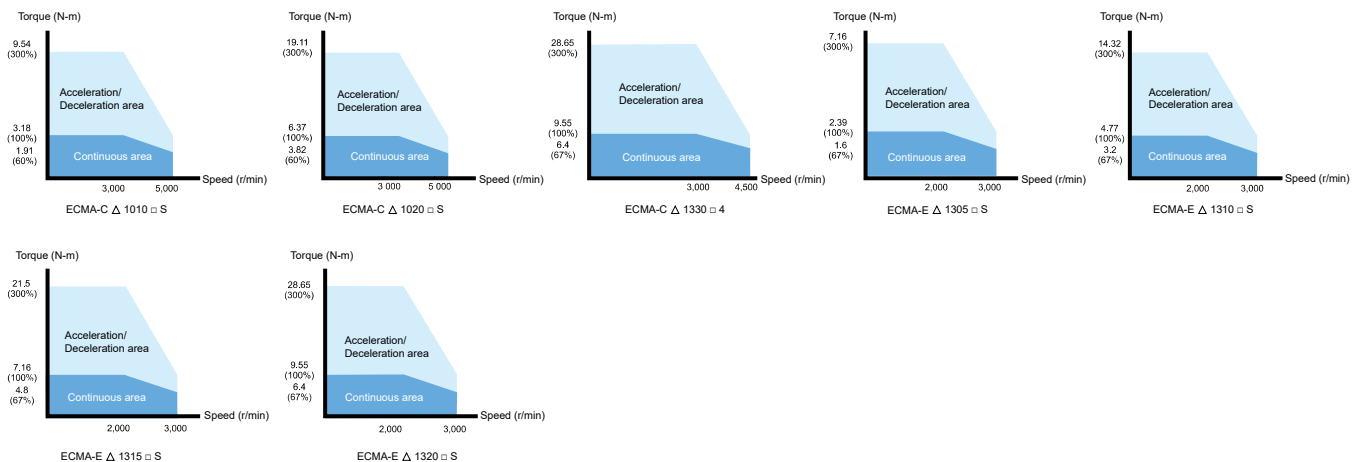

Dimensions of ECMA Series Servo Motors

Motor Frame Size: 100 ~ 130

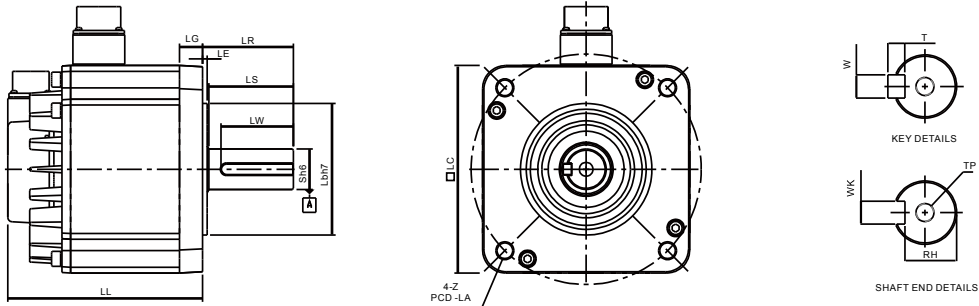

Units: mm

Model	F Δ 1305 \square S	F Δ 1308 \square S	F Δ 1313 \square S	F Δ 1318 \square S	G Δ 1303 \square S	G Δ 1306 \square S	G Δ 1309 \square S
LC	130	130	130	130	130	130	130
LZ	9	9	9	9	9	9	9
LA	145	145	145	145	145	145	145
S	22 ($^{+0}_{-0.013}$)	22 ($^{+0}_{-0.013}$)	22 ($^{+0}_{-0.013}$)	22 ($^{+0}_{-0.013}$)	22 ($^{+0}_{-0.013}$)	22 ($^{+0}_{-0.013}$)	22 ($^{+0}_{-0.013}$)
LB	110 ($^{-0.035}_{+0}$)	110 ($^{+0}_{-0.035}$)	110 ($^{+0}_{-0.035}$)	110 ($^{+0}_{-0.035}$)	110 ($^{+0}_{-0.035}$)	110 ($^{+0}_{-0.035}$)	110 ($^{+0}_{-0.035}$)
LL (without brake)	139.5	152.5	187.5	202	147.5	147.5	163.5
LL (with brake)	168	181	216	230.7	183.5	183.5	198
LS	47	47	47	47	47	47	47
LR	55	55	55	55	55	55	55
LE	6	6	6	6	6	6	6
LG	11.5	11.5	11.5	11.5	11.5	11.5	11.5
LW	36	36	36	36	36	36	36
RH	18	18	18	18	18	18	18
WK	8	8	8	8	8	8	8
W	8	8	8	8	8	8	8
T	7	7	7	7	7	7	7
TP	M6 Depth 20	M6 Depth 20	M6 Depth 20	M6 Depth 20	M6 Depth 20	M6 Depth 20	M6 Depth 20

- NOTE**
- 1) Dimensions are in millimeters.
 - 2) Dimensions and weights might be revised without prior notice.
 - 3) Box, (\square) represents the shaft end/ brake or the number of oil seal.
 - 4) The boxes (Δ) in the model names are for encoder resolution types ($\Delta=1$: Incremental encoder, 20-bit; $\Delta=2$: Incremental encoder, 17-bit).

Torque Features (T-N Curve)

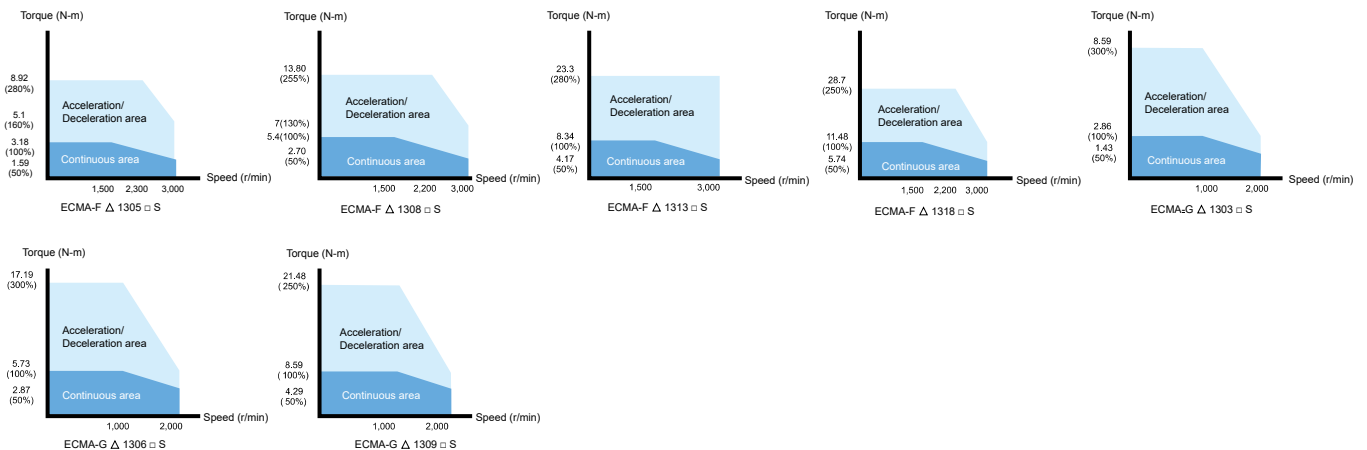

Motor Frame Size: 180 or above

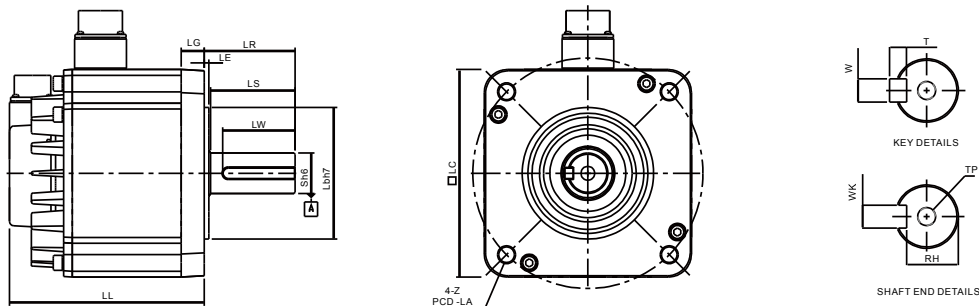

Units: mm

Model	E \triangle 1820 \square S	E \triangle 1830 \square S	F \triangle 1830 \square S	E \triangle 1835 \square S
LC	180	180	180	180
LZ	13.5	13.5	13.5	13.5
LA	200	200	200	200
S	35 (+0/-0.016)	35 (+0/-0.016)	35 (+0/-0.016)	35 (+0/-0.016)
LB	114.3 (+0/-0.035)	114.3 (+0/-0.035)	114.3 (+0/-0.035)	114.3 (+0/-0.035)
LL (without brake)	169	202.1	202.1	202.1
LL (with brake)	203.1	235.3	235.3	235.3
LS	73	73	73	73
LR	79	79	79	79
LE	4	4	4	4
LG	20	20	20	20
LW	63	63	63	63
RH	30	30	30	30
WK	10	10	10	10
W	10	10	10	10
T	8	8	8	8
TP	M12 Depth 25	M12 Depth 25	M12 Depth 25	M12 Depth 25



NOTE

- 1) Dimensions are in millimeters.
- 2) Dimensions and weights might be revised without prior notice.
- 3) Box, (\square) represents the shaft end/ brake or the number of oil seal.
- 4) The boxes (\triangle) in the model names are for encoder resolution types ($\triangle=1$: Incremental encoder, 20-bit; $\triangle=2$: Incremental encoder, 17-bit).

Torque Features (T-N Curve)

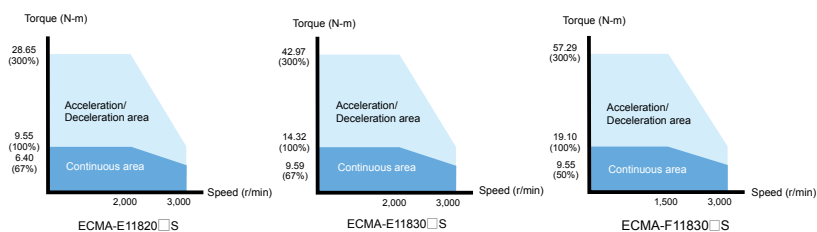

Part Names and Functions

● LED Display / Operation Panel / Charge LED

■ LED Display

The 5 digit, 7 segment LED displays the servo status or fault codes.

■ Operation Panel

Function keys used to perform status display, monitor and diagnostic, function and parameter setting.

Function Keys:

MODE : Press this key to select/change mode

SHIFT : Press this key to shift cursor to the left

UP : Press this key to increase values on the display

DOWN : Press this key to decrease values on the display

SET : Press this key to store data

■ Charge LED

A lit LED indicates that either power is connected to the servo drive or a residual charge is present in the drive's internal power components.

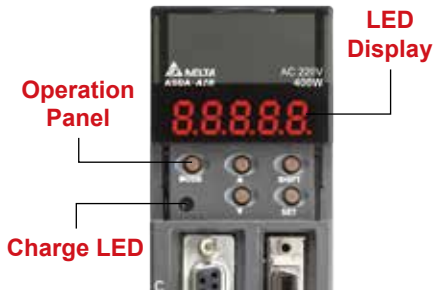

● * Full-Closed Loop Control Interface

Used to connect linear scale and encoder for controlling A, B, Z phase signals.

● I/O Interface

Used to connect Delta's DVP Series PLC or other external controllers for controlling I/O signals.

● * High-speed Communication Port

- Used to connect CANopen networks.
- 1-in/1-out communication ports offer easy serial connection.
- CANbus interface, supporting motion modes for CANopen DS402 implementation.

● Motor Encoder Interface

Used to connect the encoder of the servo motor

● Extension Digital Input Connection Port

Used to connect a removable digital input terminal block. Max.6 digital inputs can be added. (ASD-A2R-*-U models only)

● Serial Communication Port

Used to connect PLC, HMI, and other controllers for RS-485 / RS-232 serial communication.

● USB Connection Port

- Used to connect personal computers or notebooks.
- Ver 1.1 USB is equipped as standard.
- Direct connectivity to personal computers or notebooks, capable of accessing data through ASDA-Soft configuration software.
- Monitor speed upon software is up to 1Mbps.



● Internal & External Regenerative Resistor Terminal / Control Circuit Terminal / Main Circuit Terminal

■ Internal & External Regenerative Resistor Terminal

1. When using an external resistor, connect it to P \oplus and C , and ensure an open circuit between P \oplus and D.
2. When using an internal resistor, ensure the circuit is closed between P \oplus and D, and the circuit is open between P \oplus and C. (Note: Please refer to the table of regenerative resistor specifications for the models with a built-in regenerative resistor.)

3. When using an external braking unit, connect it to P \oplus and \ominus , and ensure an open circuit between P \oplus and D, and P \oplus and C

■ Control Circuit Terminal (L1C, L2C or DC24V, DC0V)

220V Series: L1C, L2C are used to connect 200~230Vac, 50/60Hz single-phase or three-phase power supply.

400V Series: DC24V, DC0V are used to connect 24Vdc \pm 10% power supply.

■ Main Circuit Terminal (R, S, T)

220V Series: Used to connect 200~230Vac, 50/60Hz commercial power supply.

400V Series: Used to connect 380~480Vac, 50/60Hz commercial power supply.

- When using an external braking unit, connect it to P \oplus and \ominus .

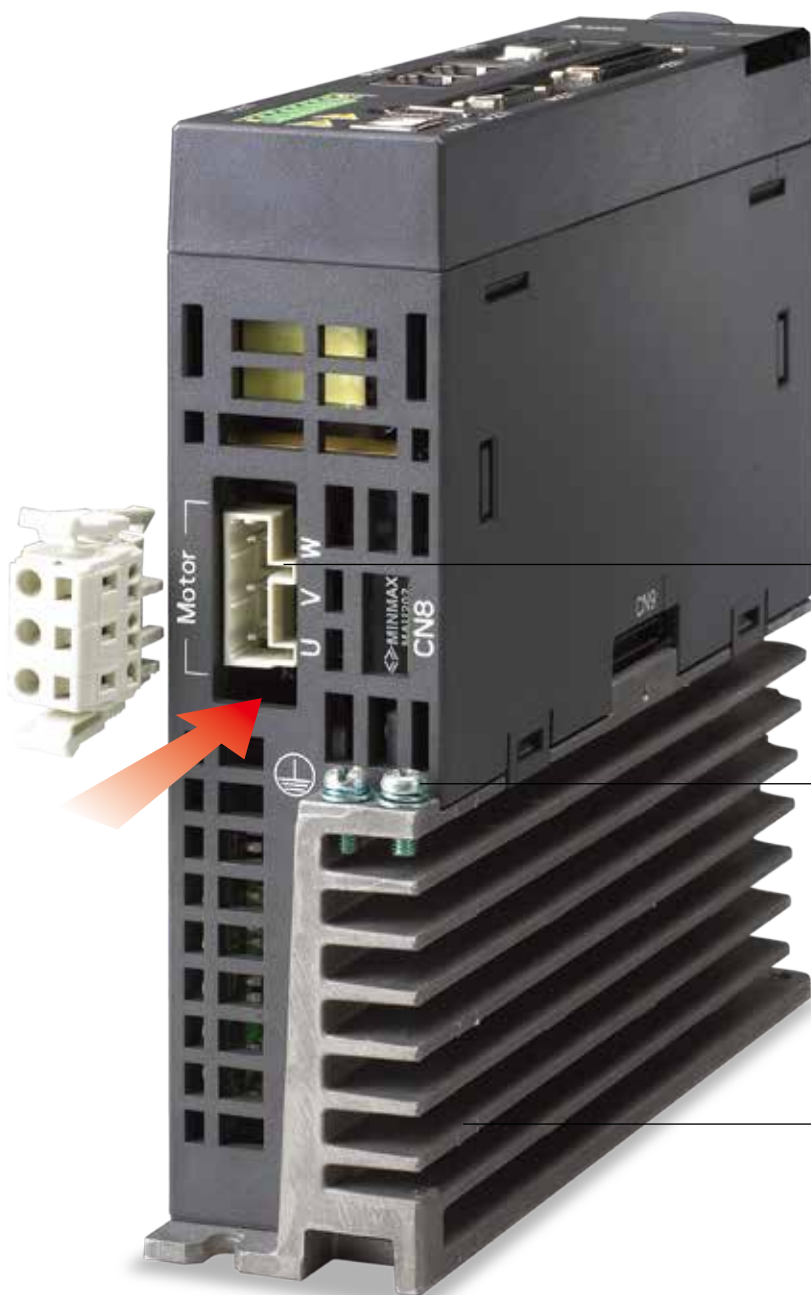

● Servo Motor Output (U, V, W)

- Used to connect servo motor. Never connect the output terminal to main circuit power as the AC drive may be damaged beyond repair if incorrect cables are connected to the output terminals.

● Ground Terminal

- Used to connect grounding wire of power supply and servo motor.

● Heatsink

- Used to secure servo drive and for heat dissipation.

Please note:
*This is a Delta optional part.

Wiring

Position (PT) Mode Standard Wiring

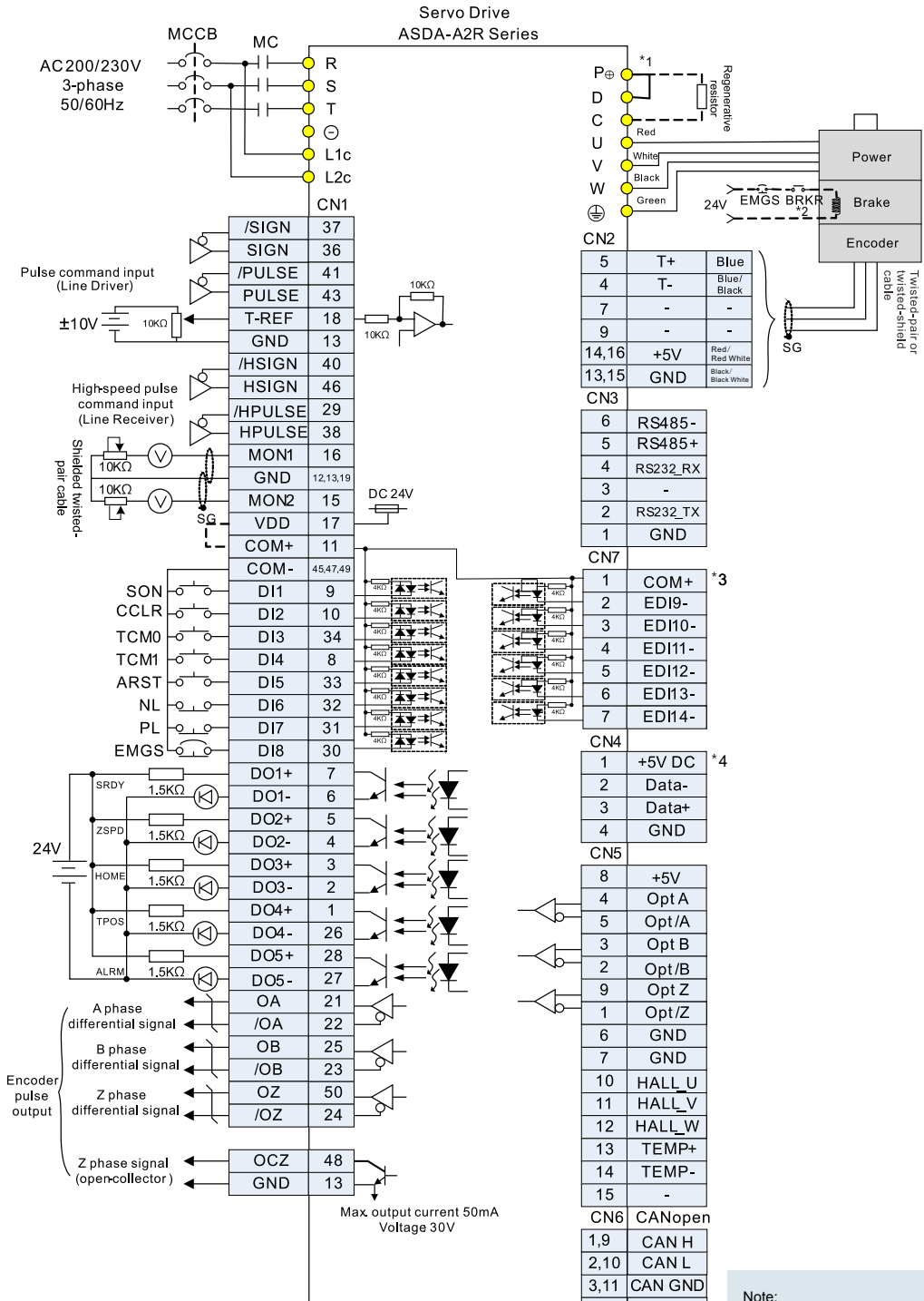
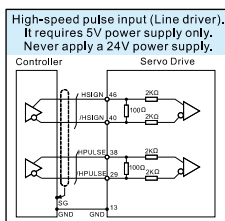
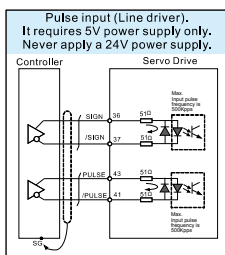
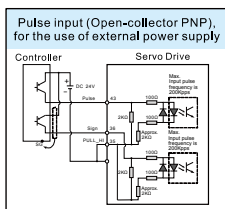
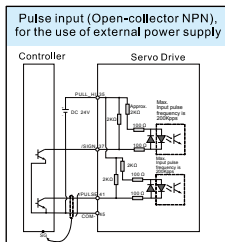
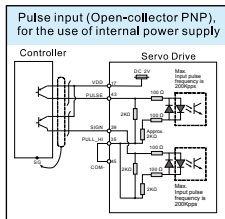
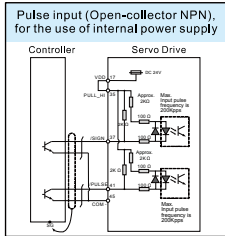

Note:
 *1. 400W and below servo drives do not provide a built-in regenerative resistor.
 *2. The brake oil has no polarity.
 *3. For extension digital inputs (optional).
 *4. For USB connection. It connects to a personal computer.

Position (PR) Control Mode (for Internal Procedure Control)

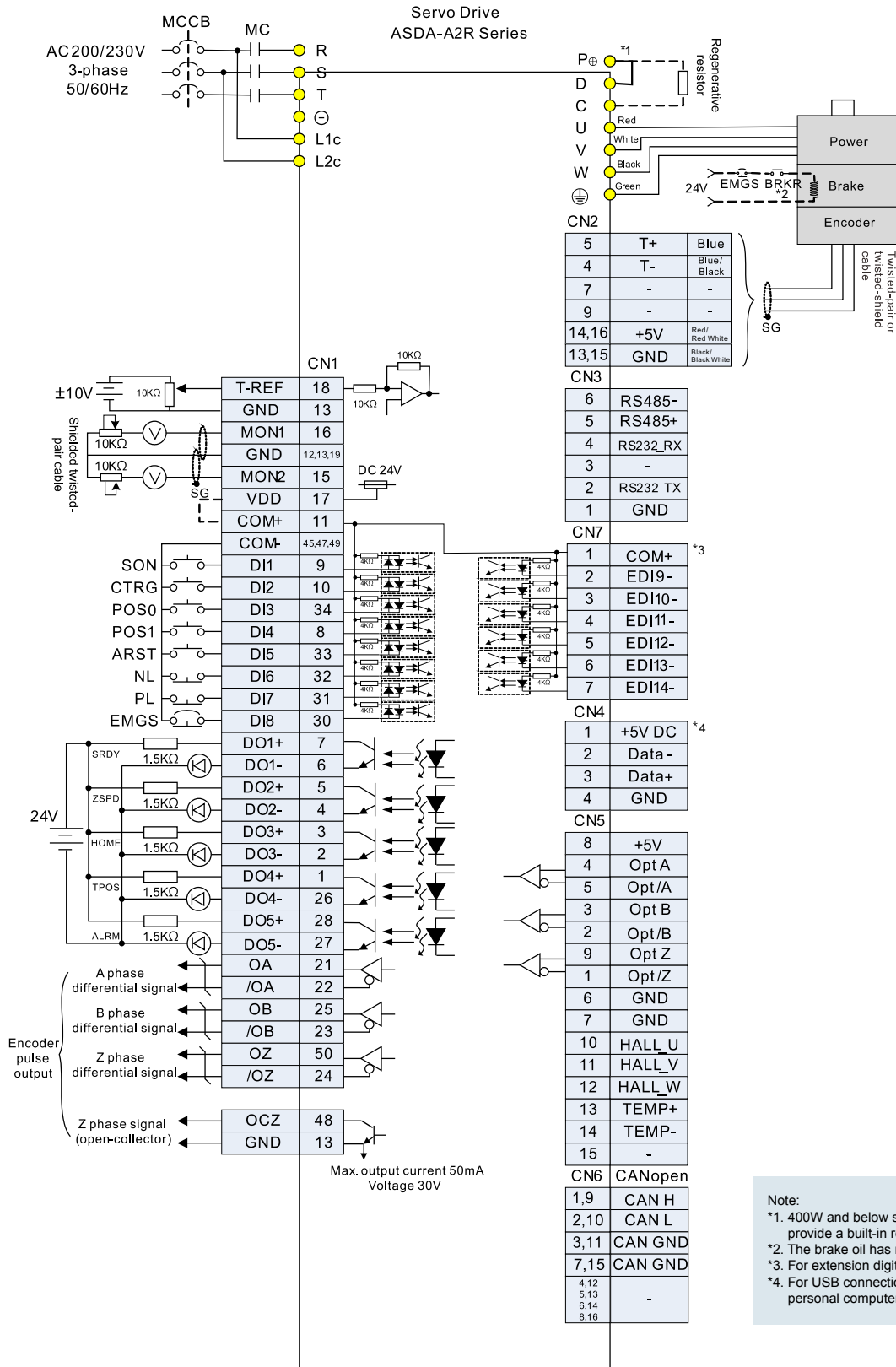

Note:
 *1. 400W and below servo drives do not provide a built-in regenerative resistor.
 *2. The brake oil has no polarity.
 *3. For extension digital inputs (optional).
 *4. For USB connection. It connects to a personal computer.



Wiring

Speed(S), Torque(T) Control Mode (for Analog Voltage Input and Internal Parameter Setting)

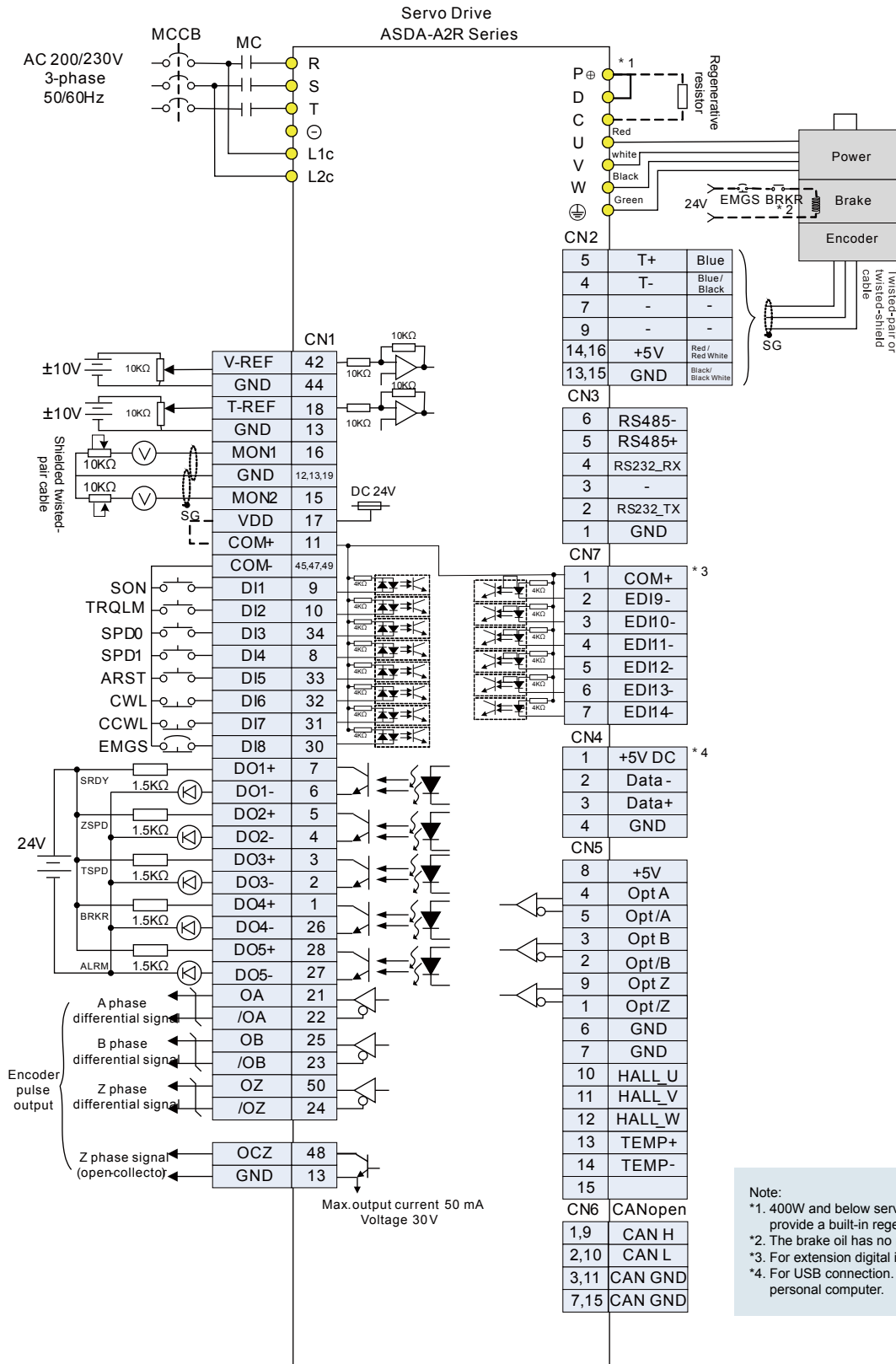

Note:
 *1. 400W and below servo drives do not provide a built-in regenerative resistor.
 *2. The brake oil has no polarity.
 *3. For extension digital inputs (optional).
 *4. For USB connection. It connects to a personal computer.

CANopen Communication Mode

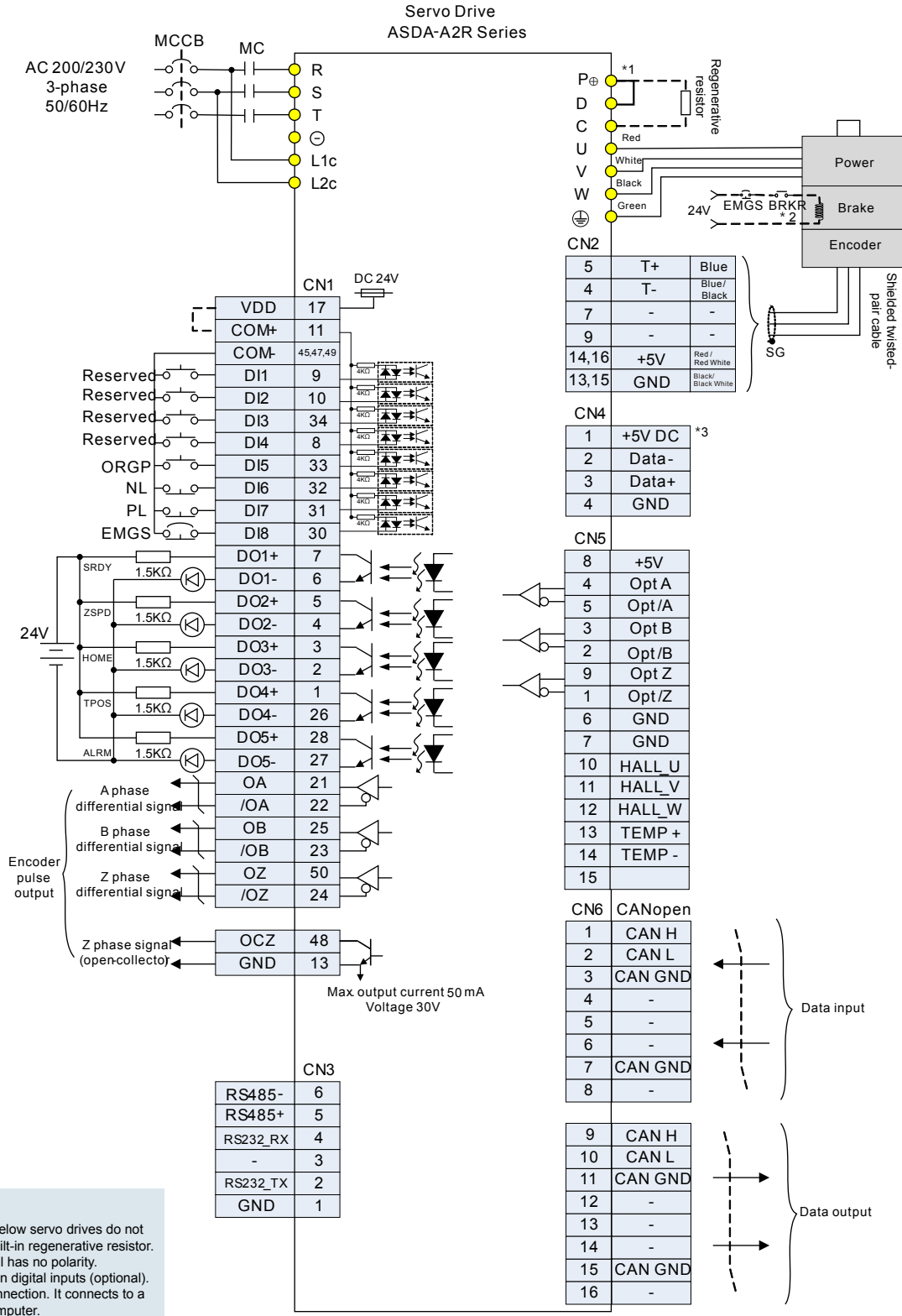

ASDA-Soft Configuration Software

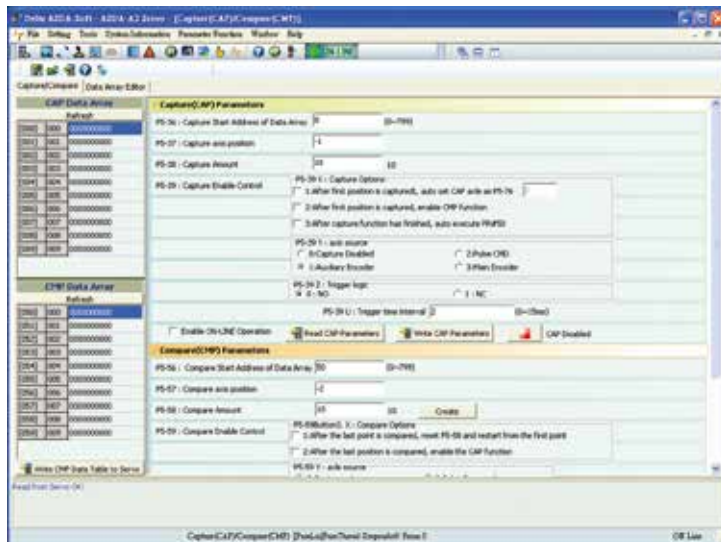

- Strong CAPTURE and COMPARE functions for position latch and detection help you complete system configuration quickly.

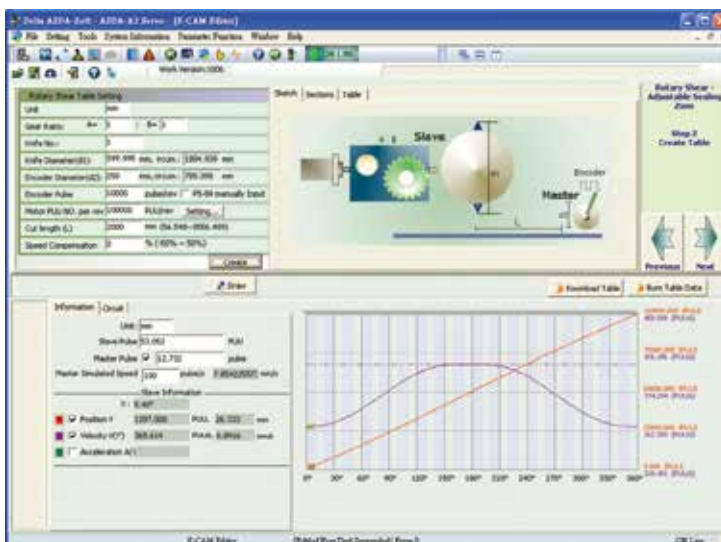

- User-friendly E-CAM editing interface is provided for designing E-CAM outlines and curves freely. In addition, quick settings for flying shear and rotary cut applications are offered.

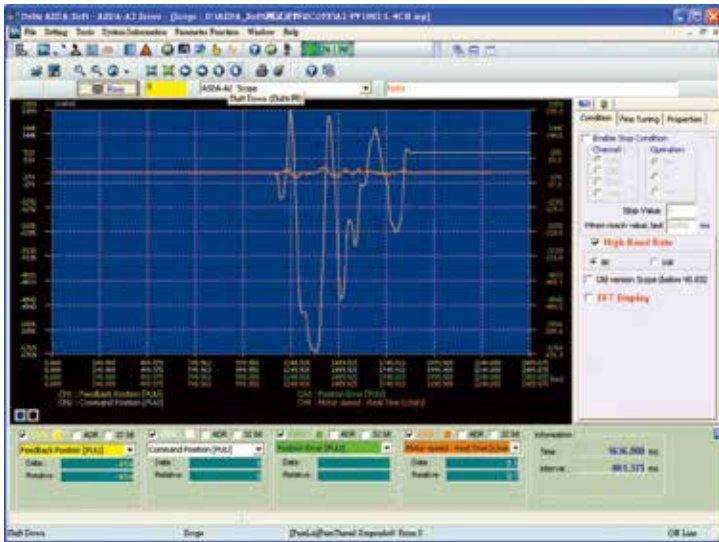

- Versatile on-line monitoring function, similar to a digital oscilloscope is able to quickly record the status and data of each axis. Real-time monitoring is easy.

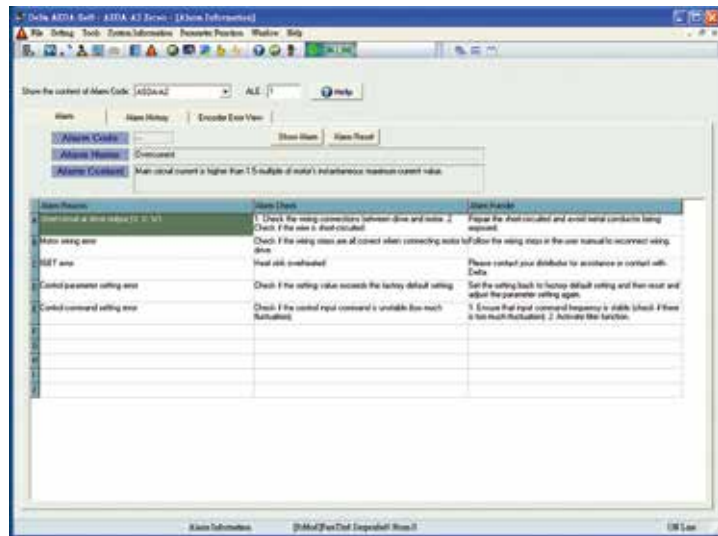

- Convenient alarm display function is capable of troubleshooting the system easily and recommending timely corrective actions.

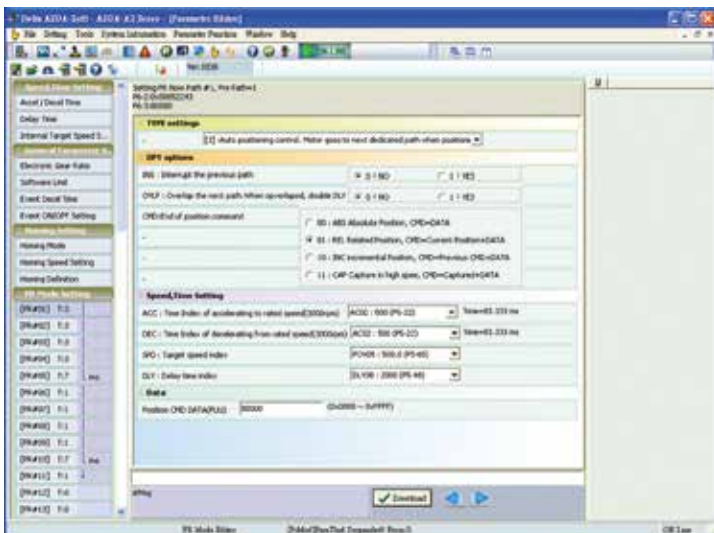

- Easy-to-use editing interface is designed for new and enhanced PR control mode. Homing, point-to-point and other motion control functions for multi-axis positioning control are easily achieved.

Optional Accessories

• Quick Connectors

- Used for 100W to 300W servo drives
- One operating lever is provided for wire to terminal block insertion.



• Power Cables

- 3m and 5m standard cables are available.
- Customized service is offered to meet the needs of customers.
- Two types are selectable: with brake and without brake.



• Encoder Cables

- 3m and 5m standard cables are available.
- Customized service is offered to meet the needs of customers.



• RS-232 Communication Cables

- Connects ASDA-A2R to PLC, HMI, and other controllers via RS-232 communication.
- Standard cable length is 3m.



• USB Communication Cables (for PC)

- Connects ASDA-A2R to a PC (via ASDA-Soft configuration software)
- USB1.1 is equipped as standard.



• RS-485 Connectors

- Used to connect multiple ASDA-A2R Series products by RS-485 interface through Modbus serial communication.





● **CN1 I/O connector**

- Delta Part Number: ASD-IF-SC5020



● **Terminal Block Modules**

- Easy installation and wiring.
- 0.5m connection cable is provided. Easy to reduce the space required.
- Easy to expand system's I/O configuration.



● **Regenerative Resistors**

- For selecting a regenerative resistor, please refer to the table of regenerative resistor specifications on page 50.



● **CANopen Accessories**

- Delta's TAP-CN03 distribution box connects ASDA-A2R to Delta's PLC CAN Master.
- CANopen communication cable is provided. Standard cable length is 0.5m and 1m.



● **ASD-IF-EN0A20 Signal Converter Box**

- Converts the square wave and sine wave to communication signals that can be used and controlled by Delta's servo drive.
- Connects ASDA-A2R to permanent-magnet synchronous linear motors and servo (rotary) motors.



SCSI 20-pin

SCSI 26-pin

● **Signal Connectors**

- For the connection of a ASD-IF-EN0A20 signal converter box.
- Two types are selectable: SCSI 26-pin and SCSI 20-pin.



● **Connection Cables**

- Connects ASDA-A2R to a ASD-IF EN0A20 signal converter box.
- 3m and 5m standard cables are available.

Servo Drive ASDA-A2R Specifications

220V Series

ASDA-A2R Series		100 W	200 W	400 W	750 W	1 kW	1.5 kW	2 kW	3 kW	
		01	02	04	07	10	15	20	30	
Power Supply	Phase / Voltage	Three-phase / Single-phase 220 V _{AC}						Three-phase 220 V _{AC}		
	Permissible Voltage Range	1-phase / 3-phase 200 ~ 230 V _{AC} , -15% ~ 10%						3-phase 200 ~ 230 V _{AC} , -15% ~ 10%		
	Input Current(3PH) (Units: Arms)	0.8	1.11	1.86	3.66	4.68	6.33	8.76	9.83	
	Input Current(1PH) (Units: Arms)	1	1.92	3.22	6.78	8.88	10.96	-	-	
	Continuous Output Current (Units: Arms)	0.9	1.55	2.6	5.1	7.3	8.86	13.4	19.4	
	Max. Output Current (Units: Arms)	7.07	10.61	10.61	14.14	21.21	35.35	53.03	70.71	
Cooling System		Natural Air Circulation				Fan Cooling				
Encoder Resolution / Feedback Resolution		20-bit (1280000 p/rev)								
Control of Main Circuit		SVPWM(Space Vector Pulse Width Modulation) Control								
Tuning Modes		Auto / Manual								
Regenerative Resistor		None			Built-in					
Position Control Mode	Max. Input Pulse Frequency (Only for Non-DMCNET mode)	Max. 500Kpps / 4Mpps (Line driver), Max. 200Kpps (Open collector)								
	Pulse Type (Only for Non-DMCNET mode)	Pulse + Direction, A phase + B phase, CCW pulse + CW pulse								
	Command Source	External pulse train (PT mode) (Only for Non-DMCNET mode) / Internal parameters (PR mode)								
	Smoothing Strategy	Low-pass and P-curve filter								
	Electronic Gear	Electronic gear N/M multiple N: 1~32767, M: 1:32767 (1/50<N/M<25600)								
	Torque Limit Operation	Set by parameters								
Feed Forward Compensation		Set by parameters								
Speed Control Mode	Analog Input Voltage Range	0 ~ ±10 V _{DC}								
	Command Input Resistance (Only for Non-DMCNET mode)	10KΩ								
	Time Constant	2.2 μs								
	Speed Control Range ^{**1}	1: 5000								
	Command Source	External analog signal (Only for Non-DMCNET mode) / Internal parameters								
	Smoothing Strategy	Low-pass and S-curve filter								
	Torque Limit Operation	Set by parameters or via analog input (Only for Non-DMCNET mode)								
	Frequency Response Characteristic	Maximum 1 kHz								
Speed Accuracy ^{**2} (At rated rotation speed)	0.01% or less at 0 to 100% load fluctuation									
	0.01% or less at ±10% power fluctuation									
	0.01% or less at 0°C to 50°C ambient temperature fluctuation									
Torque Control Mode	Analog Input Voltage Range	0 ~ ±10 V _{DC}								
	Command Input Resistance (Only for Non-DMCNET mode)	10KΩ								
	Time Constant	2.2 μs								
	Command Source	External analog signal (Only for Non-DMCNET mode) / Internal parameters								
Smoothing Strategy		Low-pass filter								
Speed Limit Operation		Set by parameters or via analog input (Only for Non-DMCNET mode)								
Analog Monitor Output		Monitor signal can be set by parameters (Output voltage range: ±8V)								
Digital Inputs / Outputs	Inputs	Servo on, Reset, Gain switching, Pulse clear, Zero speed CLAMP, Command input reverse control, Command triggered, Speed/ Torque limit enabled, Position command selection, Motor stop, Speed position selection, Position / Speed mode switching, Speed / Torque mode switching, Torque / Position mode switching, PT / PR command switching, Emergency stop, Forward / Reverse inhibit limit, Reference "Home" sensor, Forward / Reverse operation torque limit, Move to "Home", Electronic CAM (E-CAM), Forward / Reverse JOG input, Event trigger PR command, Electronic gear ratio (Numerator) selection and Pulse inhibit input								
	Outputs	Encoder signal output (A, B, Z Line Driver and Z Open Collector) Servo ready, Servo on, At Zero speed, At Speed reached, At Positioning completed, At Torques limit, Servo alarm (Servo fault) activated, Electromagnetic brake control, Homing completed, Output overload warning, Servo warning activated, Position command overflow, Forward / Reverse software limit, Internal position command completed, Capture operation completed output., Motion control completed output., Master position of E-CAM (Electronic CAM)								
Protective Functions		Overcurrent, Overvoltage, Undervoltage, Motor overheated, Regeneration error, Overload, Overspeed, Abnormal pulse control command, Excessive deviation, Encoder error, Adjustment error, Emergency stop activated, Reverse/ Forward limit switch error, Position excessive deviation of full-close control loop, Serial communication error, Input power phase loss, Serial communication time out, short circuit protection of U, V, W, and CN1, CN2, CN3 terminals								
Communication Interface		RS-232 / RS-485 / CANopen / USB / DMCNET								
Environment	Installation Site	Indoor location (free from direct sunlight), no corrosive liquid and gas (far away from oil mist, flammable gas, dust)								
	Altitude	Altitude 2000 m or lower above sea level								
	Atmospheric Pressure	86 kPa ~ 106 kPa								
	Operating Temperature	0°C ~ 55°C (If operating temperature is above 45°C, forced cooling will be required)								
	Storage Temperature	-20°C ~ 65°C								
	Humidity	0 ~ 90% RH (non-condensing)								
	Vibration	9.80665 m/s (1G) less than 20Hz, 5.88 m/s (0.6G) 20 to 50Hz								
	IP Rating	IP20								
Power System	TN System ^{**3}									
Approvals		IEC/EN 61800-5-1, UL 508C, C-tick		CE		cUL US LISTED		V		

Footnote:

*1. Rated rotation speed: When full load, speed ratio is defined as the minimum speed (the motor will not pause).

*2. When command is rated rotation speed, the speed fluctuation rate is defined as: (Empty load rotation speed / Full load rotation speed) / Rated rotation speed

*3. TN system: A power distribution system having one point directly earthed, the exposed conductive parts of the installation being connected to that points by protective earth conductor.

Dimensions of ASDA-A2R Servo Drives

220V Series

100W / 200W / 400W

Weight
1.5 (3.3)

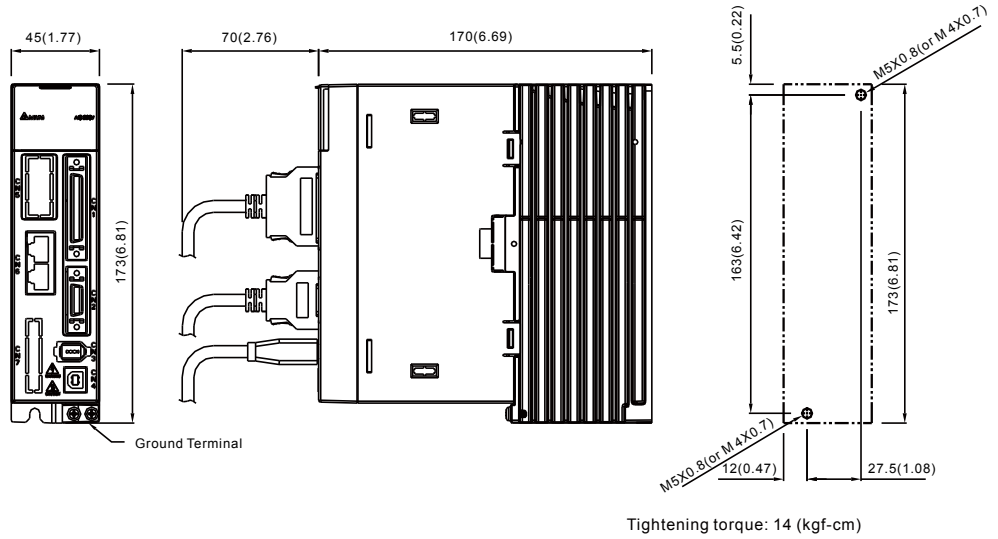

750W / 1.0kW / 1.5kW

Weight
2.0 (4.4)

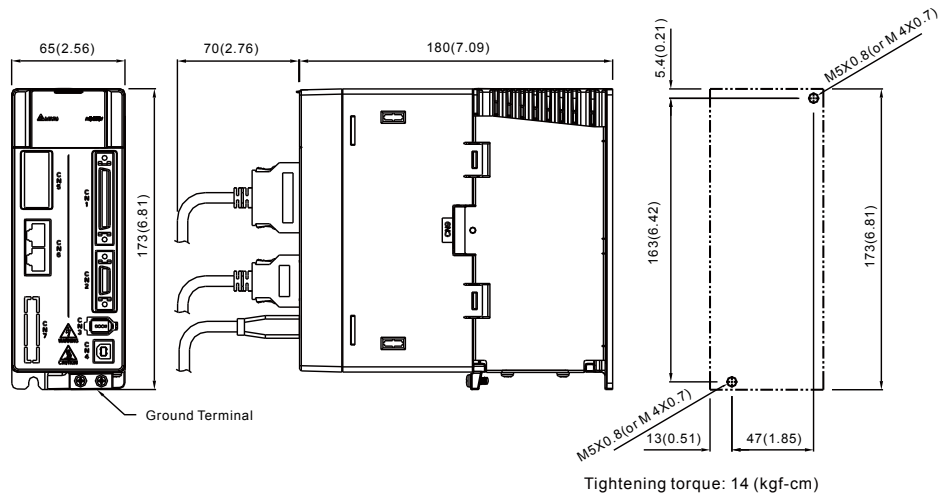

2.0kW / 3.0kW

Weight
2.89 (6.36)

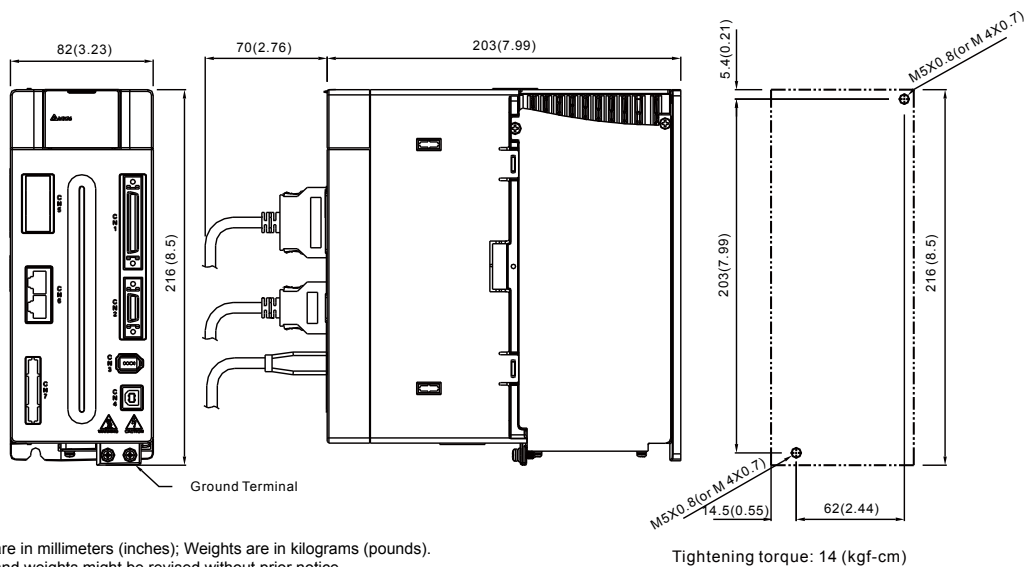

NOTE 1) Dimensions are in millimeters (inches); Weights are in kilograms (pounds).
2) Dimensions and weights might be revised without prior notice.

Optional Accessories

• Power Connectors

ASDBCAPW0000

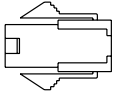

ASD-CAPW1000

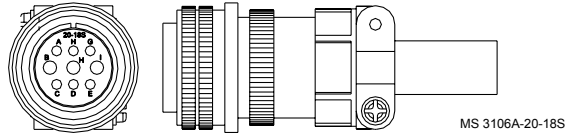

ASDBCAPW0100

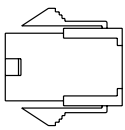

ASD-CAPW2000

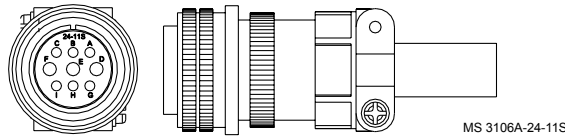

• Power Cables

ASD-ABPW0003, ASD-ABPW0005

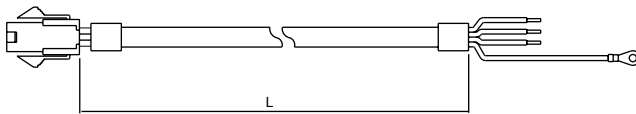

Item	Part No.	L	
		mm	inch
1	ASD-ABPW0003	3000 ± 100	118 ± 4
2	ASD-ABPW0005	5000 ± 100	197 ± 4

ASD-ABPW0103, ASD-ABPW0105

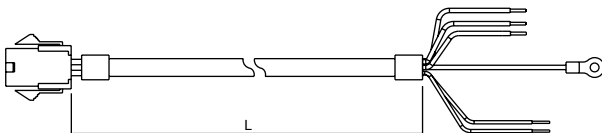

Item	Part No.	L	
		mm	inch
1	ASD-ABPW0103	3000 ± 100	118 ± 4
2	ASD-ABPW0105	5000 ± 100	197 ± 4

ASD-CAPW1003, ASD-CAPW1005

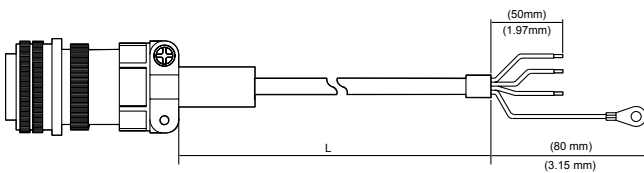

Item	Part No.	Straight	L	
			mm	inch
1	ASD-CAPW1003	3106A-20-18S	3000 ± 100	118 ± 4
2	ASD-CAPW1005	3106A-20-18S	5000 ± 100	197 ± 4

ASD-A2PW1103, ASD-A2PW1105

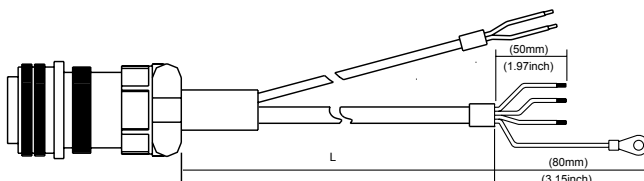

Item	Part No.	Straight	L	
			mm	inch
1	ASD-A2PW1103	3106A-20-18S	3000 ± 100	118 ± 4
2	ASD-A2PW1105	3106A-20-18S	5000 ± 100	197 ± 4

● Power Cables

ASD-A2PW1003, ASD-A2PW1005

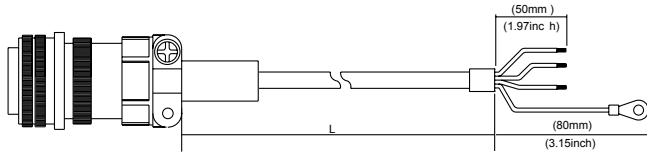

Item	Part No.	Straight	L	
			mm	inch
1	ASD-A2PW1003	3106A-20-18S	3000 ± 100	118 ± 4
2	ASD-A2PW1005	3106A-20-18S	5000 ± 100	197 ± 4

ASD-A2PW1103, ASD-A2PW1105

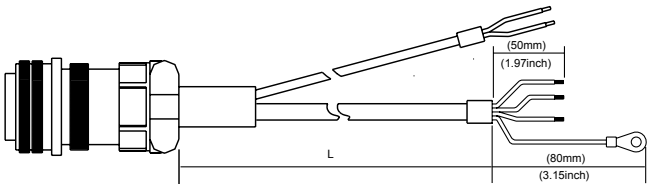

Item	Part No.	Straight	L	
			mm	inch
1	ASD-A2PW1103	3106A-20-18S	3000 ± 100	118 ± 4
2	ASD-A2PW1105	3106A-20-18S	5000 ± 100	197 ± 4

ASD-CAPW2003, ASD-CAPW2005

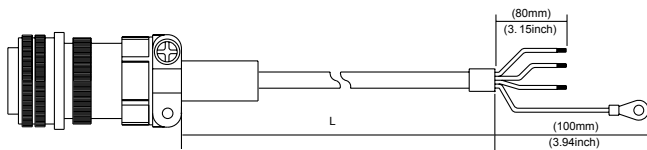

Item	Part No.	Straight	L	
			mm	inch
1	ASD-CAPW2003	3106A-24-11S	3000 ± 100	118 ± 4
2	ASD-CAPW2005	3106A-24-11S	5000 ± 100	197 ± 4

ASD-CAPW2103, ASD-CAPW2105

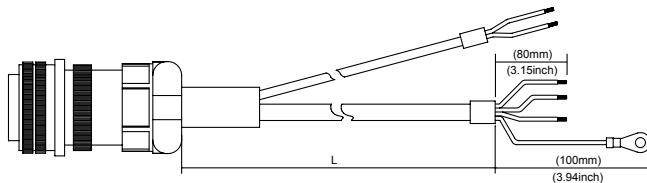

Item	Part No.	Straight	L	
			mm	inch
1	ASD-CAPW2103	3106A-24-11S	3000 ± 100	118 ± 4
2	ASD-CAPW2105	3106A-24-11S	5000 ± 100	197 ± 4

● Encoder Connectors

ASD-ABEN0000

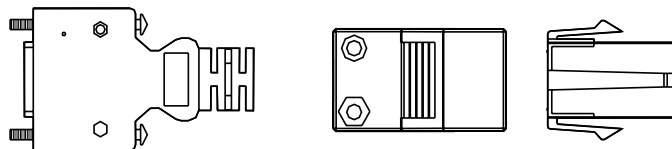

ASD-CAEN1000

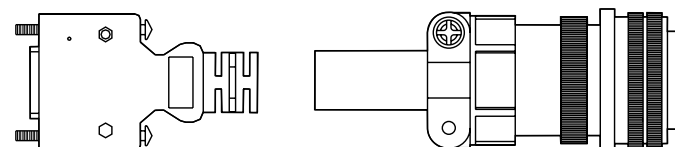

Optional Accessories

Incremental Encoder Cables

ASD-ABEN0003, ASD-ABEN0005

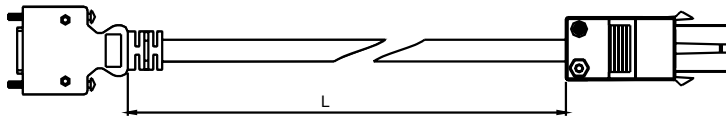

Item	Part No.	L	
		mm	inch
1	ASD-ABEN0003	3000 ± 100	118 ± 4
2	ASD-ABEN0005	5000 ± 100	197 ± 4

ASD-CAEN1003, ASD-CAEN1005

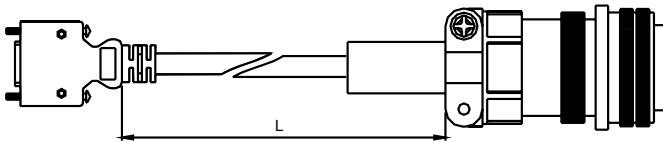

Item	Part No.	Straight	L	
			mm	inch
1	ASD-CAEN1003	3106A-20-29S	3000 ± 100	118 ± 4
2	ASD-CAEN1005	3106A-20-29S	5000 ± 100	197 ± 4

ASD-IF-EN0A20 Signal Converter Box

Dimensions are in mm (in.)

ASD-IF-EN0A20

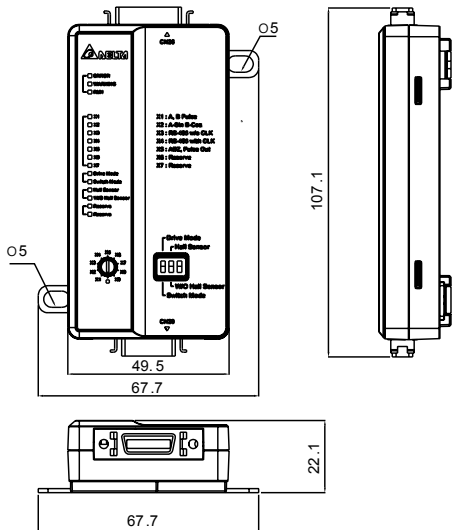

SCSI 26pin Connector

Dimensions are in mm (in.)

ASD-CNSC0026

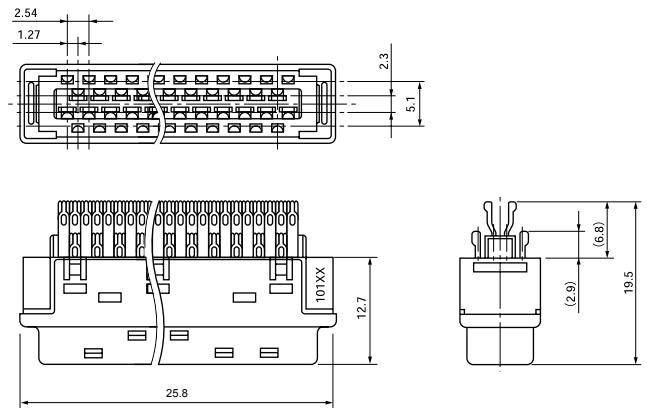

SCSI 20pin Connector

Dimensions are in mm (in.)

ASD-CNSC0020

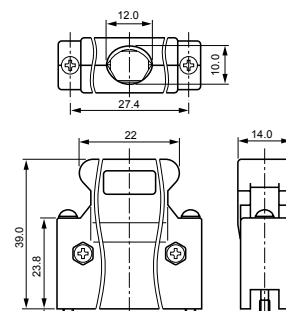

● Absolute Encoder Cables

ASD-CASC2003, ASD-CASC2005

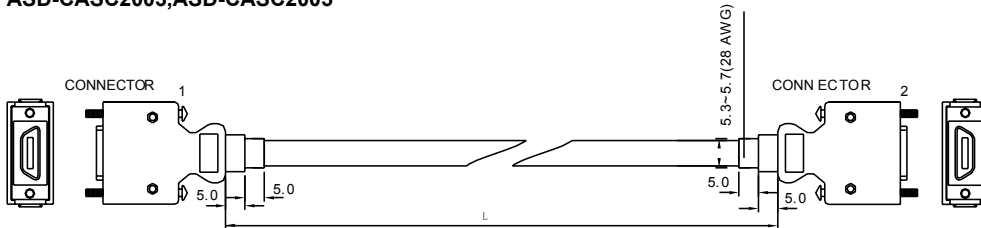

Item	Part No.	mm (AWG)	Type	L	
				mm	inch
1	ASD-CASC2003	5.3~5.7 (28AWG)	UL2464	3000 ± 100	118 ± 4
2	ASD-CASC2005	5.3~5.7 (28AWG)	UL2464	5000 ± 100	197 ± 4

● IO Signal Connector (CN1)

ASD-CN5C0050

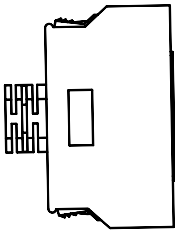

● CN1 Connector

Dimensions are in mm (in.)

ASD-IF-SC5020

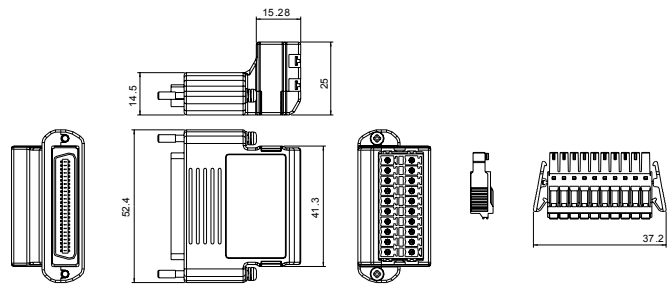

● RS-485 Connector

Dimensions are in mm (in.)

ASD-CNIE0B06

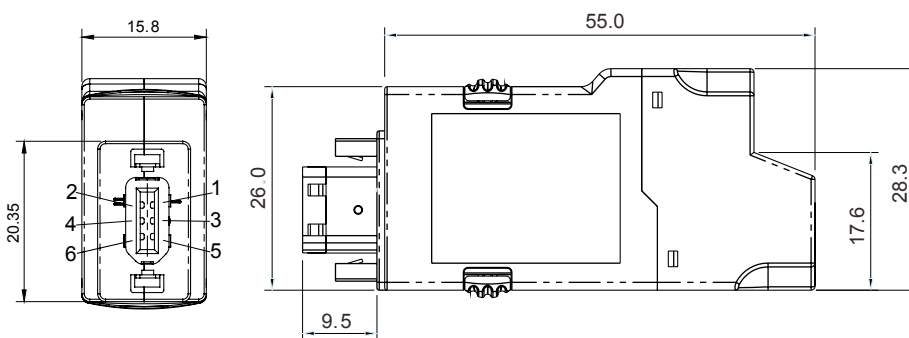

● RS-232 Communication Cable

ASD-CARS0003

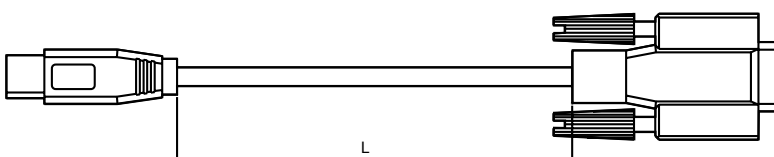

Item	Part No.	L	
		mm	inch
1	ASD-CARS0003	3000 ± 100	118 ± 4

Optional Accessories

Terminal Block Module Dimensions are in mm (in.)

ASD-BM-50A

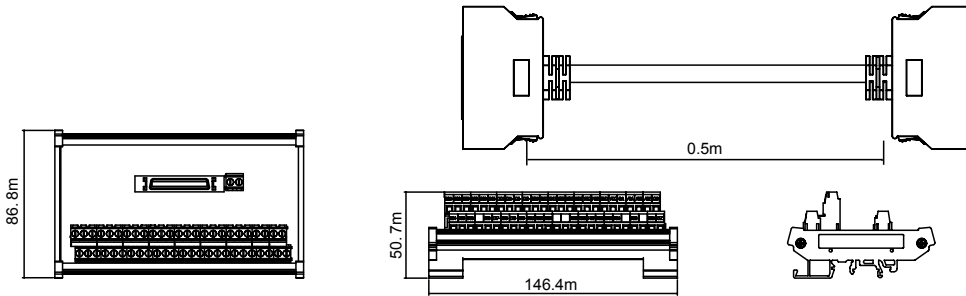

Terminal Block Module

TAP-CB03, TAP-CB05

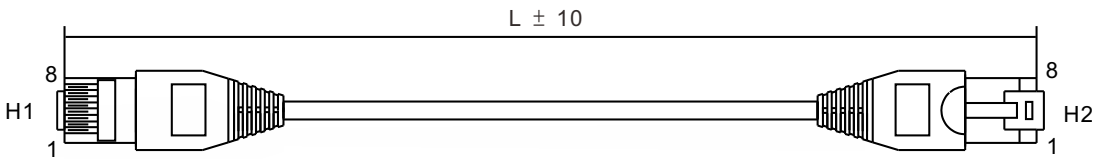

Item	Part No.	L	
		mm	inch
1	TAP-CB03	300±10	11±0.4
2	TAP-CB05	500±10	19±0.4

CANopen Distribution Box Dimensions are in mm (in.)

TAP-CN03

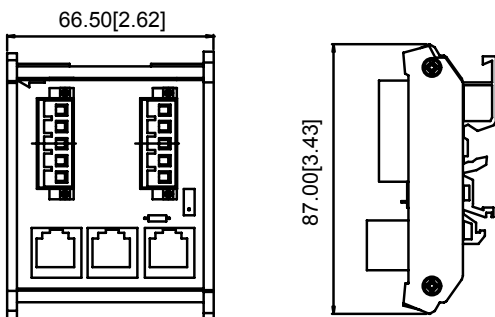

1) More accessories for ASDA-A2R will be on the list.
2) Accessories images shown here may differ from the actual product.

● Communication Cable between Drive and Computer (for PC)

DOP-CAUSBAB

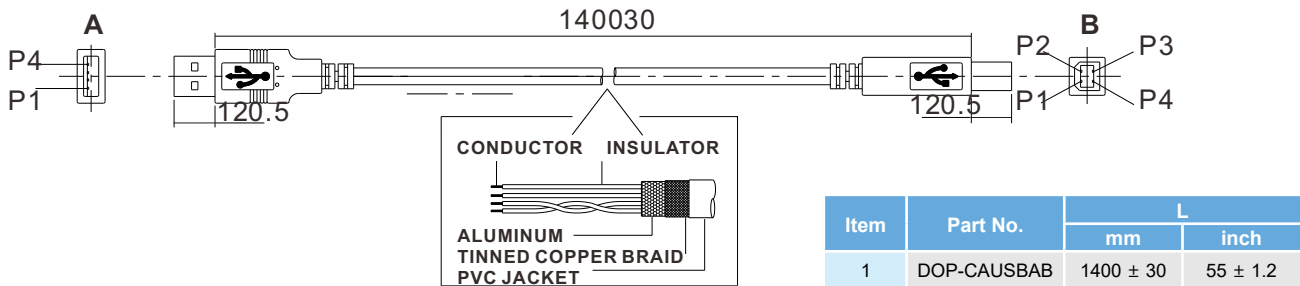

1) More accessories for ASDA-A2R will be on the list.
2) Accessories images shown here may differ from the actual product.

Safety Information

Global Standards	ASDA-A2R Series is designed to fully comply with demanding international standards, such as IEC, EN and more for all fields of industrial automation technology.	
EMC standard	EN61000-4-6	Level 3
	EN61000-4-3	Level 3
	EN61000-4-2	Level 2 and Level 3
	EN61000-4-4	Level 3
	EN61000-4-8	Level 4
	EN61000-4-5	Level 3
Conducted & Radiated Emissions	Complies with EN550011 Class A Group 1, with external EMC filter	
CE Marking	CE recognized. Complies with Directive 2006/95/EC of the European Parliament and EMC Directive 2004/108/EC.	
UL Approval	UL (U.S.), cUL (Canada) recognized.	
Test Standard	IEC/EN50178, IEC/EN60529	
	IP20	
Vibration	1G less than 20Hz, 0.6G 20 to 50Hz. Complies with IEC/EN50178	
Shock	15gn 11ms. Complies with IEC/EN600028-2-27	
Pollution Degree	Degree 2. Complies with IEC/EN61800-5-1	

Servo Drive, Servo Motor and Accessories Combinations - Corresponding ECMA Rotary Motors

100W Servo Drive and 50W Low Inertia Servo Motor

Servo Drive	ASD-A2R-0121-□
Low Inertia Servo Motor	ECMA-C1040F □ S
Power Cable (Without Brake)	ASD-ABPW000X
Power Connectors (Without Brake)	ASDBCAPW0000
Power Cable (With Brake)	ASD-ABPW010X
Power Connector (With Brake)	ASDBCAPW0100
Incremental Encoder Cable	ASD-ABEN000X
Absolute Encoder Cable	ASD-A2EB000X
Encoder Connector	ASD-ABEN0000

100W Servo Drive and 100W Low Inertia Servo Motor

Servo Drive	ASD-A2R-0121-□
Low Inertia Servo Motor	ECMA-C△0401 □ S
Power Cable (Without Brake)	ASD-ABPW000X
Power Connectors (Without Brake)	ASDBCAPW0000
Power Cable (With Brake)	ASD-ABPW010X
Power Connector (With Brake)	ASDBCAPW0100
Incremental Encoder Cable	ASD-ABEN000X
Absolute Encoder Cable	ASD-A2EB000X
Encoder Connector	ASD-ABEN0000

200W Servo Drive and 200W Low Inertia Servo Motor

Servo Drive	ASD-A2R-0221-□
Low Inertia Servo Motor	ECMA-C△0602 □ S
Power Cable (Without Brake)	ASD-ABPW000X
Power Connectors (Without Brake)	ASDBCAPW0000
Power Cable (With Brake)	ASD-ABPW010X
Power Connector (With Brake)	ASDBCAPW0100
Incremental Encoder Cable	ASD-ABEN000X
Absolute Encoder Cable	ASD-A2EB000X
Encoder Connector	ASD-ABEN0000

400W Servo Drive and 400W Low Inertia Servo Motor

Servo Drive	ASD-A2R-0421-□
Low Inertia Servo Motor	ECMA-C△0401 □ S ECMA-C△0804 □ 7
Power Cable (Without Brake)	ASD-ABPW000X
Power Connectors (Without Brake)	ASDBCAPW0000
Power Cable (With Brake)	ASD-ABPW010X
Power Connector (With Brake)	ASDBCAPW0100
Incremental Encoder Cable	ASD-ABEN000X
Absolute Encoder Cable	ASD-A2EB000X
Encoder Connector	ASD-ABEN0000

400W Servo Drive and 600W Medium Inertia Servo Motor

Servo Drive	ASD-A2R-0421-□
Medium Inertia Servo Motor	ECMA-E△1305 □ S
Power Cable (Without Brake)	ASD-CAPW100X
Power Cable (With Brake)	ASD-CAPW110X
Power Connector	ASD-CAPW1000
Incremental Encoder Cable	ASD-CAEN100X
Absolute Encoder Cable	ASD-A2EB100X
Encoder Connector	ASD-CAEN1000

400W Servo Drive and 300W High Inertia Servo Motor

Servo Drive	ASD-A2R-0421-□
High Inertia Servo Motor	ECMA-G△1303 □ S
Power Cable (Without Brake)	ASD-CAPW100X
Power Cable (With Brake)	ASD-CAPW110X
Power Connector	ASD-CAPW1000
Incremental Encoder Cable	ASD-CAEN100X
Absolute Encoder Cable	ASD-A2EB100X
Encoder Connector	ASD-CAEN1000

750W Servo Drive and 500W Medium-High Inertia Servo Motor

Servo Drive	ASD-A2R-0721-□
High Inertia Servo Motor	ECMA-F11305 □ S
Power Cable (Without Brake)	ASD-CAPW100X
Power Cable (With Brake)	ASD-CAPW110X
Power Connector	ASD-CAPW1000
Incremental Encoder Cable	ASD-CAEN100X
Absolute Encoder Cable	ASD-A2EB100X
Encoder Connector	ASD-CAEN1000

750W Servo Drive and 750W Low Inertia Servo Motor

Servo Drive	ASD-A2R-0721-□
Low Inertia Servo Moto	ECMA-C△0807 □ S ECMA-C△0907 □ 7
Power Cable (Without Brake)	ASD-ABPW000X
Power Connectors (Without Brake)	ASDBCAPW0000
Power Cable (With Brake)	ASD-ABPW010X
Power Connector (With Brake)	ASDBCAPW0100
Incremental Encoder Cable	ASD-ABEN000X
Absolute Encoder Cable	ASD-A2EB000X
Encoder Connector	ASD-ABEN0000



X=3 indicates that the cable length is 3m
X=5 indicates that the cable length is 5m

750W Servo Drive and 600W High Inertia Servo Motor

Servo Drive	ASD-A2R-0721-□
High Inertia Servo Motor	ECMA-G△1306 □ S
Power Cable (Without Brake)	ASD-CAPW100X
Power Cable (With Brake)	ASD-CAPW110X
Power Connector	ASD-CAPW1000
Incremental Encoder Cable	ASD-CAEN100X
Absolute Encoder Cable	ASD-A2EB100X
Encoder Connector	ASD-CAEN1000

1kW Servo Drive and 1kW Low Inertia Servo Motor

Servo Drive	ASD-A2R-1021-□
Low Inertia Servo Motor	ECMA-C△1010 □ S
Power Cable (Without Brake)	ASD-CAPW100X
Power Cable (With Brake)	ASD-CAPW110X
Power Connector	ASD-CAPW1000
Incremental Encoder Cable	ASD-CAEN100X
Absolute Encoder Cable	ASD-A2EB100X
Encoder Connector	ASD-CAEN1000

1kW Servo Drive and 1kW Low Inertia Servo Motor

Servo Drive	ASD-A2R-1021-□
Low Inertia Servo Motor	ECMA-C△0910 □ S
Power Cable (Without Brake)	ASD-ABPW000X
Power Cable (With Brake)	ASDBCAPW0000
Power Connector	ASD-ABPW010X
Incremental Encoder Cable	ASDBCAPW0100
Absolute Encoder Cable	ASD-ABEN000X
Encoder Connector	ASD-ABEN0000

1kW Servo Drive and 1kW Medium Inertia Servo Moto

Servo Drive	ASD-A2R-1021-□
Medium Inertia Servo Motor	ECMA-E△1310 □ S
Power Cable (Without Brake)	ASD-CAPW100X
Power Cable (With Brake)	ASD-CAPW110X
Power Connector	ASD-CAPW1000
Incremental Encoder Cable	ASD-CAEN100X
Absolute Encoder Cable	ASD-A2EB100X
Encoder Connector	ASD-CAEN1000

1kW Servo Drive and 850W Medium-High Inertia Servo Motor

Servo Drive	ASD-A2R-1021-□
Medium-High Inertia Servo Motor	ECMA-F△1308 □ S
Power Cable (Without Brake)	ASD-CAPW100X
Power Cable (With Brake)	ASD-CAPW110X
Power Connector	ASD-CAPW1000
Incremental Encoder Cable	ASD-CAEN100X
Absolute Encoder Cable	ASD-A2EB100X
Encoder Connector	ASD-CAEN1000

1kW Servo Drive and 1.5kW Medium Inertia Servo Moto

Servo Drive	ASD-A2R-1521-□
Medium Inertia Servo Motor	ECMA-E△1315 □ S
Power Cable (Without Brake)	ASD-CAPW100X
Power Cable (With Brake)	ASD-CAPW110X
Power Connector	ASD-CAPW1000
Incremental Encoder Cable	ASD-CAEN100X
Absolute Encoder Cable	ASD-A2EB100X
Encoder Connector	ASD-CAEN1000

1kW Servo Drive and 900W High Inertia Servo Motor

Servo Drive	ASD-A2R-1021-□
High Inertia Servo Motor	ECMA-G△1309 □ S
Power Cable (Without Brake)	ASD-CAPW100X
Power Cable (With Brake)	ASD-CAPW110X
Power Connector	ASD-CAPW1000
Incremental Encoder Cable	ASD-CAEN100X
Absolute Encoder Cable	ASD-A2EB100X
Encoder Connector	ASD-CAEN1000

2kW Servo Drive and 2kW Low Inertia Servo Motor

Servo Drive	ASD-A2R-2023-□
Low Inertia Servo Motor	ECMA-C△1020 □ S
Power Cable (Without Brake)	ASD-A2PW100X
Power Cable (With Brake)	ASD-A2PW110X
Power Connector	ASD-CAPW1000
Incremental Encoder Cable	ASD-CAEN100X
Absolute Encoder Cable	ASD-A2EB100X
Encoder Connector	ASD-CAEN1000



X=3 indicates that the cable length is 3m
X=5 indicates that the cable length is 5m

Servo Drive, Servo Motor and Accessories Combinations - Corresponding ECMA Rotary Motors

2kW Servo Drive and 2kW Medium Inertia Servo Motor

Servo Drive	ASD-A2R-2023-□
Medium Inertia Servo Motor	ECMA-E△1320 □ S
Power Cable (Without Brake)	ASD-A2PW100X
Power Cable (With Brake)	ASD-A2PW110X
Power Connector	ASD-CAPW1000
Incremental Encoder Cable	ASD-CAEN100X
Absolute Encoder Cable	ASD-A2EB100X
Encoder Connector	ASD-CAEN1000

2kW Servo Drive and 2kW Medium Inertia Servo Motor

Servo Drive	ASD-A2R-2023-□
Medium Inertia Servo Motor	ECMA-E△1820 □ S
Power Cable (Without Brake)	ASD-CAPW100X
Power Cable (With Brake)	ASD-CAPW210X
Power Connector	ASD-CAPW2000
Incremental Encoder Cable	ASD-CAEN100X
Absolute Encoder Cable	ASD-A2EB100X
Encoder Connector	ASD-CAEN1000

2kW Servo Drive and 1.3kW Medium-High Inertia Servo Motor

Servo Drive	ASD-A2R-2023-□
Medium-High Inertia Servo Motor	ECMA-F11313 □ S
Power Cable (Without Brake)	ASD-A2PW100X
Power Cable (With Brake)	ASD-A2PW110X
Power Connector	ASD-CAPW1000
Incremental Encoder Cable	ASD-CAEN100X
Absolute Encoder Cable	ASD-A2EB100X
Encoder Connector	ASD-CAEN1000

2kW Servo Drive and 1.8kW Medium-High Inertia Servo Motor

Servo Drive	ASD-A2R-2023-□
Medium-High Inertia Servo Motor	ECMA-F11318 □ S
Power Cable (Without Brake)	ASD-A2PW100X
Power Cable (With Brake)	ASD-A2PW110X
Power Connector	ASD-CAPW1000
Incremental Encoder Cable	ASD-CAEN100X
Absolute Encoder Cable	ASD-A2EB100X
Encoder Connector	ASD-CAEN1000

3kW Servo Drive and 3 kW Low Inertia Servo Motor

Servo Drive	ASD-A2R-3023-□
Low Inertia Servo Motor	ECMA-C△1330 □ 4
Power Cable (Without Brake)	ASD-A2PW100X
Power Cable (With Brake)	ASD-A2PW110X
Power Connector	ASD-CAPW1000
Incremental Encoder Cable	ASD-CAEN100X
Absolute Encoder Cable	ASD-A2EB100X
Encoder Connector	ASD-CAEN1000

3kW Servo Drive and 3kW Medium Inertia Servo Motor

Servo Drive	ASD-A2R-3023-□
Medium Inertia Servo Motor	ECMA-E△1830 □ S
Power Cable (Without Brake)	ASD-CAPW200X
Power Cable (With Brake)	ASD-CAPW210X
Power Connector	ASD-CAPW2000
Incremental Encoder Cable	ASD-CAEN100X
Absolute Encoder Cable	ASD-A2EB100X
Encoder Connector	ASD-CAEN1000

3kW Servo Drive and 3.5kW Medium Inertia Servo Motor

Servo Drive	ASD-A2R-3023-□
Medium Inertia Servo Motor	ECMA-E△1835 □ S
Power Cable (Without Brake)	ASD-CAPW200X
Power Cable (With Brake)	ASD-CAPW210X
Power Connector	ASD-CAPW2000
Incremental Encoder Cable	ASD-CAEN100X
Absolute Encoder Cable	ASD-A2EB100X
Encoder Connector	ASD-CAEN1000

3kW Servo Drive and 3kW Medium-High Inertia Servo Motor

Servo Drive	ASD-A2R-3023-□
Medium-High Inertia Servo Motor	ECMA-F△1830 □ S
Power Cable (Without Brake)	ASD-CAPW200X
Power Cable (With Brake)	ASD-CAPW210X
Power Connector	ASD-CAPW2000
Incremental Encoder Cable	ASD-CAEN100X
Absolute Encoder Cable	ASD-A2EB100X
Encoder Connector	ASD-CAEN1000



NOTE

X=3 indicates that the cable length is 3m
X=5 indicates that the cable length is 5m

Servo Drive, Servo Motor and Accessories Combinations

Other Accessories (for ASDA-A2R Series all models)	
Description	Delta Part Number
50Pin I/O signal connector (CN1)	ASD-CN5C0050
Terminal Block Module	ASD-BM-50A
RS-232 Communication Cable	ASD-CARS0003
Communication Cable between Drive and Computer (for PC)	DOP-CAUSBAB
CANopen Communication Cable	TAP-CB03 / TAP-CB04
CANopen Distribution Box	TAP-CN03
RS-485 Connector	ASD-CNIE0B06
Regenerative Resistor 400W 40Ω	BR400W040
Regenerative Resistor 1kW 20Ω	BR1K0W020
Regenerative Resistor 1.5kW 10Ω	BR1K5W005

Regenerative Resistor Specifications

Servo Drive (kW)	Specifications of Built-in Regenerative Resistors		Min. Allowable Resistance (Ohm)
	Resistance (parameter P1-52) (Ohm)	Capacity (parameter P1-53) (Watt)	
0.1	-	-	30Ω
0.2	-	-	30Ω
0.4	40W	40W	30Ω
0.75	40W	60W	20Ω
1.0	40W	60W	20Ω
1.5	40W	60W	20Ω
2.0	20W	100W	10Ω
3.0	20W	100W	10Ω

Note:

- 400W ~ 4.5kW servo drives provide a built-in regenerative resistor.
- When the fault, ALE05 (Regeneration Error) occurs, please increase the regenerative resistor capacity or decrease the regenerative resistor resistance (the regenerative resistor resistance should not be less than the minimum allowable resistance listed in the above table.)
- If the situation is not improved after increasing the regenerative resistor capacity or decreasing the regenerative resistor resistance, please purchase regenerative resistor module.
- When combining multiple small-capacity regenerative resistors in parallel to increase the regenerative resistor capacity, make sure that the total resistance value of the regenerative resistors should not be less than the minimum allowable resistance listed in the above table.



Smarter. Greener. Together.

Industrial Automation Headquarters

Taiwan: Delta Electronics, Inc.

Taoyuan Technology Center
No.18, Xinglong Rd., Taoyuan District,
Taoyuan City 33068, Taiwan
TEL: +886-3-362-6301 / FAX: +886-3-371-6301

Asia

China: Delta Electronics (Shanghai) Co., Ltd.

No.182 Minyu Rd., Pudong Shanghai, P.R.C.
Post code : 201209
TEL: +86-21-6872-3988 / FAX: +86-21-6872-3996
Customer Service: 400-820-9595

Japan: Delta Electronics (Japan), Inc.

Industrial Automation Sales Department
2-1-14 Shibadaimon, Minato-ku
Tokyo, Japan 105-0012
TEL: +81-3-5733-1155 / FAX: +81-3-5733-1255

Korea: Delta Electronics (Korea), Inc.

1511, 219, Gasan Digital 1-Ro., Geumcheon-gu,
Seoul, 08501 South Korea
TEL: +82-2-515-5305 / FAX: +82-2-515-5302

Singapore: Delta Energy Systems (Singapore) Pte Ltd.

4 Kaki Bukit Avenue 1, #05-04, Singapore 417939
TEL: +65-6747-5155 / FAX: +65-6744-9228

India: Delta Electronics (India) Pvt. Ltd.

Plot No.43, Sector 35, HSIIDC Gurgaon,
PIN 122001, Haryana, India
TEL: +91-124-4874900 / FAX: +91-124-4874945

Thailand: Delta Electronics (Thailand) PCL.

909 Soi 9, Moo 4, Bangpoo Industrial Estate (E.P.Z),
Pattana 1 Rd., T.Phraksa, A.Muang,
Samutprakarn 10280, Thailand
TEL: +66-2709-2800 / FAX: +66-2709-2827

Australia: Delta Electronics (Australia) Pty Ltd.

Unit 20-21/45 Normanby Rd., Notting Hill Vic 3168, Australia
TEL: +61-3-9543-3720

Americas

USA: Delta Electronics (Americas) Ltd.

5101 Davis Drive, Research Triangle Park, NC 27709, U.S.A.
TEL: +1-919-767-3813 / FAX: +1-919-767-3969

Brazil: Delta Electronics Brazil

Rua Itapeva, 26 - 3º, andar Edifício Itapeva,
One - Bela Vista 01332-000 - São Paulo - SP - Brazil
TEL: +55-12-3932-2300 / FAX: +55-12-3932-237

Mexico: Delta Electronics International Mexico S.A. de C.V.

Gustavo Baz No. 309 Edificio E PB 103
Colonia La Loma, CP 54060
Tlalnepantla, Estado de México
TEL: +52-55-3603-9200

EMEA

EMEA Headquarters: Delta Electronics (Netherlands) B.V.

Sales: Sales.IA.EMEA@deltaww.com
Marketing: Marketing.IA.EMEA@deltaww.com
Technical Support: iatechnicalsupport@deltaww.com
Customer Support: Customer-Support@deltaww.com
Service: Service.IA.emea@deltaww.com
TEL: +31(0)40 800 3900

BENELUX: Delta Electronics (Netherlands) B.V.

Automotive Campus 260, 5708 JZ Helmond, The Netherlands
Mail: Sales.IA.Benelux@deltaww.com
TEL: +31(0)40 800 3900

DACH: Delta Electronics (Netherlands) B.V.

Coesterweg 45, D-59494 Soest, Germany
Mail: Sales.IA.DACH@deltaww.com
TEL: +49(0)2921 987 0

France: Delta Electronics (France) S.A.

ZI du bois Challand 2, 15 rue des Pyrénées,
Lisses, 91090 Evry Cedex, France
Mail: Sales.IA.FR@deltaww.com
TEL: +33(0)1 69 77 82 60

Iberia: Delta Electronics Solutions (Spain) S.L.U

Ctra. De Villaverde a Vallecas, 265 1º Dcha Ed.
Hormigueras – P.I. de Vallecas 28031 Madrid
TEL: +34(0)91 223 74 20

Carrer Llacuna 166, 08018 Barcelona, Spain

Mail: Sales.IA.Iberia@deltaww.com

Italy: Delta Electronics (Italy) S.r.l.

Via Meda 2-22060 Novedrate(CO)
Piazza Grazioli 18 00186 Roma Italy
Mail: Sales.IA.Italy@deltaww.com
TEL: +39 039 8900365

Russia: Delta Energy System LLC

Vereyskaya Plaza II, office 112 Vereyskaya str.
17 121357 Moscow Russia
Mail: Sales.IA.RU@deltaww.com
TEL: +7 495 644 3240

Turkey: Delta Greentech Elektronik San. Ltd. Sti. (Turkey)

Şerifali Mah. Hendem Cad. Kule Sok. No:16-A
34775 Ümraniye – İstanbul
Mail: Sales.IA.Turkey@deltaww.com
TEL: + 90 216 499 9910

MEA: Eltek Dubai (Eltek MEA DMCC)

OFFICE 2504, 25th Floor, Saba Tower 1,
Jumeirah Lakes Towers, Dubai, UAE
Mail: Sales.IA.MEA@deltaww.com
TEL: +971(0)4 2690148